

FINAL JEE(Advanced) EXAMINATION - 2020**(Held On Sunday 27th SEPTEMBER, 2020)****PAPER-1****TEST PAPER WITH SOLUTION****PART-2 : CHEMISTRY****SECTION-1 : (Maximum Marks : 18)**

- This section contains **SIX (06)** questions.
- Each question has **FOUR** options. **ONLY ONE** of these four options is the correct answer.
- For each question, choose the option corresponding to the correct answer.
- Answer to each question will be evaluated according to the following marking scheme :

<i>Full Marks</i>	: +3	If ONLY the correct option is chosen;
<i>Zero Marks</i>	: 0	If none of the options is chosen (i.e. the question is unanswered);
<i>Negative Marks</i>	: -1	In all other cases.

1. If the distribution of molecular speeds of a gas is as per the figure shown below, then the ratio of the most probable, the average and the roots mean square speeds, respectively, is

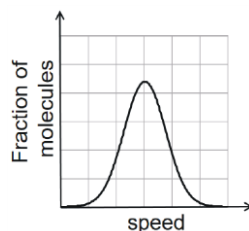

- (A) 1 : 1 : 1
 (B) 1 : 1 : 1.224
 (C) 1 : 1.128 : 1.224
 (D) 1 : 1.128 : 1

Ans. (B)

Sol. Graph represents symmetrical distribution of speed and hence, the most probable and the average speed should be same. But the root mean square speed must be greater than the average speed.

2. Which of the following liberates O₂ upon hydrolysis?

- (A) Pb₃O₄ (B) KO₂ (C) Na₂O₂ (D) Li₂O₂

Ans. (B)

Sol. (A) Pb₃O₄ is insoluble in water or do not react with water.

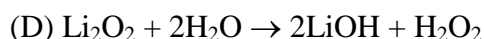
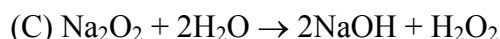
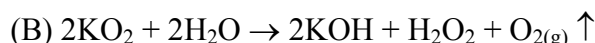

3. A colorless aqueous solution contains nitrates of two metals, **X** and **Y**. When it was added to an aqueous solution of NaCl, a white precipitate was formed. This precipitate was found to be partly soluble in hot water to give a residue **P** and a solution **Q**. The residue **P** was soluble in aq. NH₃ and also in excess sodium thiosulfate. The hot solution **Q** gave a yellow precipitate with KI. The metals **X** and **Y**, respectively, are

- (A) Ag and Pb (B) Ag and Cd (C) Cd and Pb (D) Cd and Zn

Ans. (A)

Sol. X : Ag

P : AgCl

Y : Pb

Q : PbCl₂

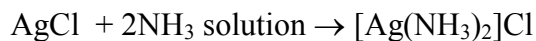
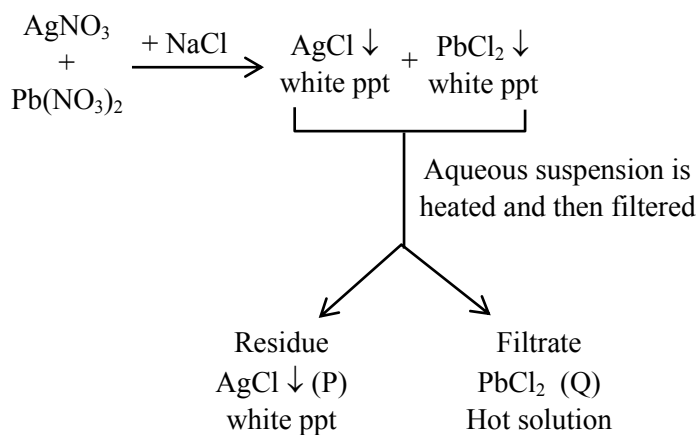

(P) (excess) clear solution

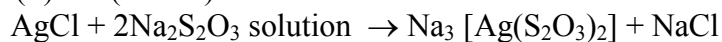

(P) (excess) clear solution

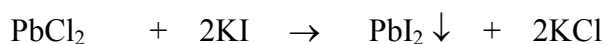

Hot solution (yellow ppt)

(Q)

4. Newman projections P, Q, R and S are shown below :

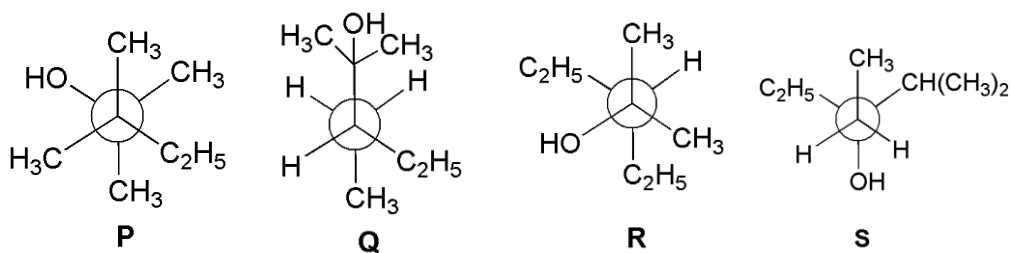

Which one of the following options represents identical molecules ?

(A) P and Q

(B) Q and S

(C) Q and R

(D) R and S

Ans. (C)

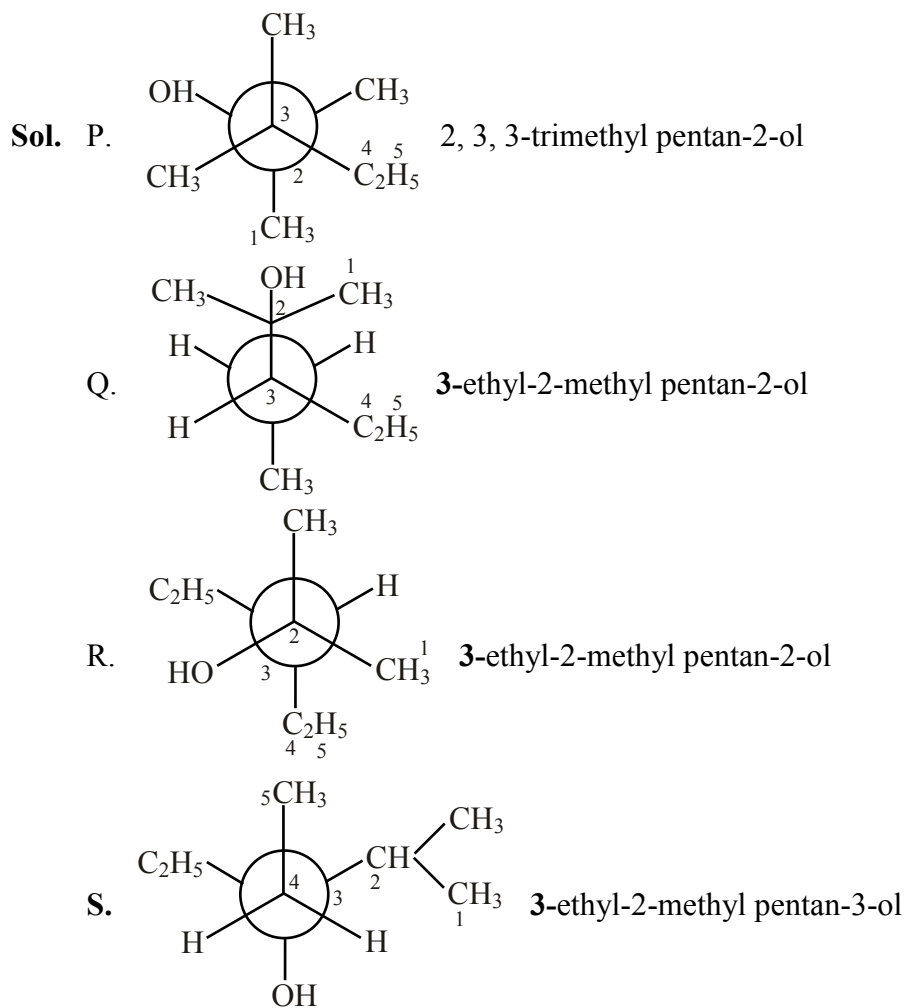

Q and R is same.

5. Which one of the following structures has the IUPAC name

3-ethynyl-2-hydroxy-4-methylhex-3-en-5-ynoic acid ?

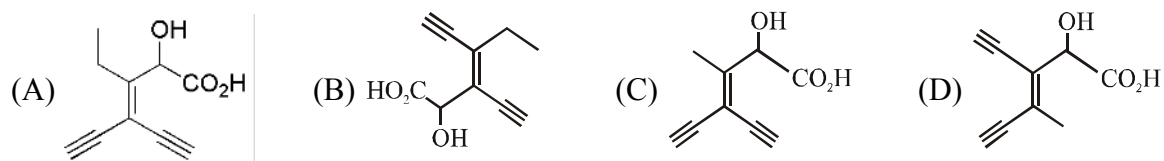

Ans. (D)

Sol.

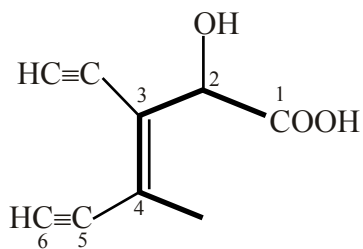

3-ethynyl-2-hydroxy-4-methyl-hex-3-en-5-ynoic acid.

6. The Fischer projection of D-erythrose is shown below.

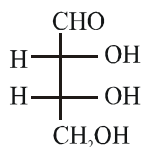

D-Erythrose

D-Erythrose and its isomers are listed as **P**, **Q**, **R**, and **S** in **Column-I**. Choose the correct relationship of **P**, **Q**, **R**, and **S** with D-erythrose from **Column II**.

Column-I

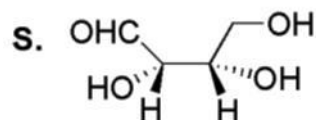
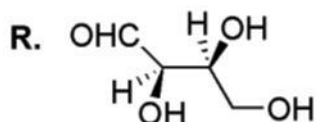
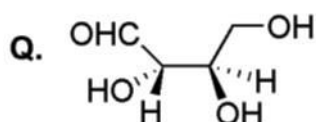
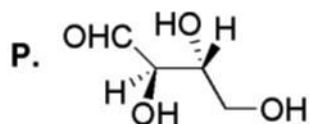

Column-II

1. Diastereomer

2. Identical

3. Enantiomer

(A) P → 2, Q → 3, R → 2, S → 2

(B) P → 3, Q → 1, R → 1, S → 2

(C) P → 2, Q → 1, R → 1, S → 3

(D) P → 2, Q → 3, R → 3, S → 1

Ans. (C)

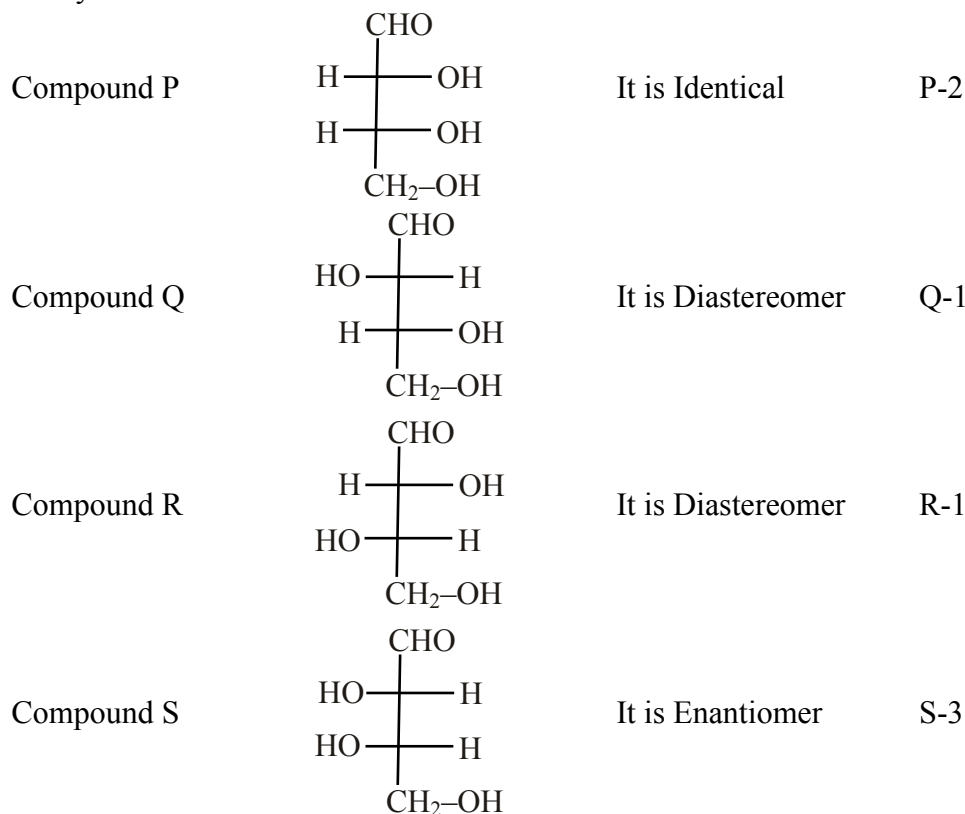
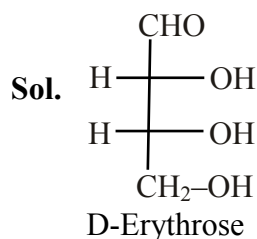

Ans. P-2, Q-1, R-1, S-3

SECTION-2 : (Maximum Marks : 24)

- This section contains **SIX (06)** questions.
- Each question has **FOUR** options. **ONE OR MORE THAN ONE** of these four option(s) is(are) correct answer(s).
- For each question, choose the option(s) corresponding to (all) the correct answer(s).
- Answer to each question will be evaluated according to the following marking scheme :

<i>Full Marks</i>	: +4	If only (all) the correct option(s) is(are) chosen;
<i>Partial Marks</i>	: +3	If all the four options are correct but ONLY three options are chosen;
<i>Partial Marks</i>	: +2	If three or more options are correct but ONLY two options are chosen, both of which are correct;
<i>Partial Marks</i>	: +1	If two or more options are correct but ONLY one option is chosen and it is a correct option;
<i>Zero Marks</i>	: 0	If none of the options is chose (i.e. the question is unanswered);
<i>Negative Marks</i>	: -2	In all other cases

7. In thermodynamics the P-V work done is given by

$$w = -\int dV P_{\text{ext}}$$

For a system undergoing a particular process, the work done is ,

$$w = -\int dV \left(\frac{RT}{V-b} - \frac{a}{V^2} \right)$$

This equation is applicable to a

- (A) System that satisfies the van der Waals equation of state.
 (B) Process that is reversible and isothermal.
 (C) Process that is reversible and adiabatic.
 (D) Process that is irreversible and at constant isothermal.

Ans. (A, B, C)

Sol. For 1 mole Vander Waal's gas

$$P = \frac{RT}{V-b} - \frac{a}{V^2}$$

If $P_{\text{ext}} = P$, means process is reversible. For Vanderwaal gas, expression is correct for all reversible process.

8. With respect to the compounds I-V, choose the correct statement(s).

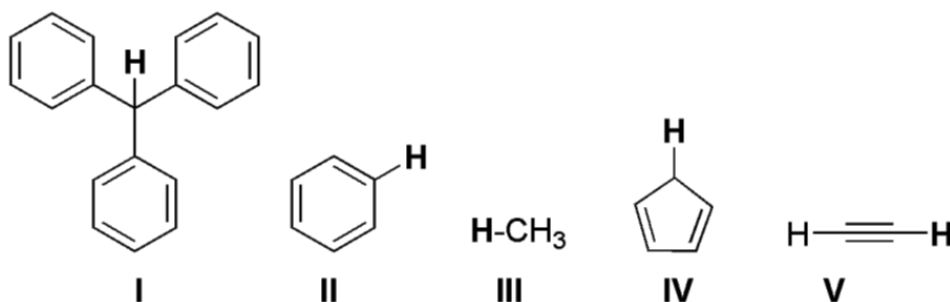

- (A) The acidity of compound **I** is due to delocalization in the conjugate base.
 (B) The conjugate base of compound **IV** is aromatic.
 (C) Compound **II** becomes more acidic, when it has a $-\text{NO}_2$ substituent.
 (D) The acidity of compounds follows the order **I** > **IV** > **V** > **II** > **III**.

Ans. (A, B, C)

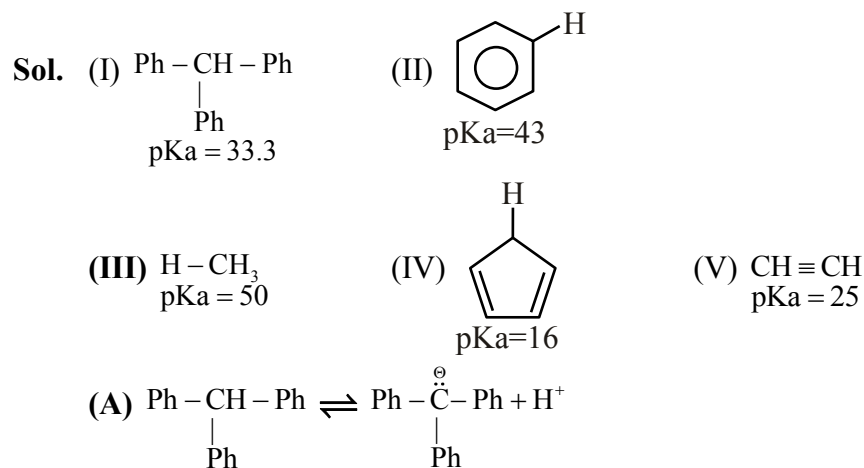

(Resonance stabilised)

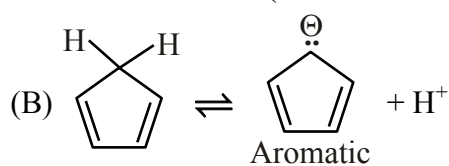

(C) $-\text{NO}_2$ is $-I$ group (electron withdrawing group). It increases acid strength.

(D) Acid strength order : $\text{IV} > \text{V} > \text{I} > \text{II} > \text{III}$

9. In the reaction scheme shown below **Q**, **R** and **S** are the major products.

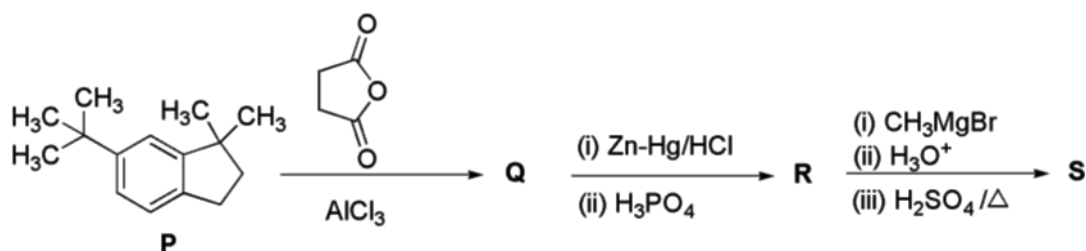

The correct structure of

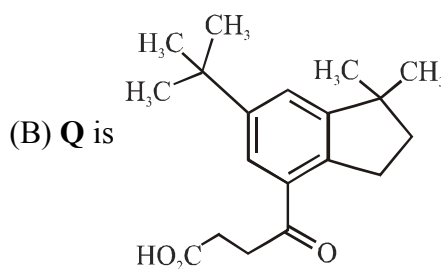
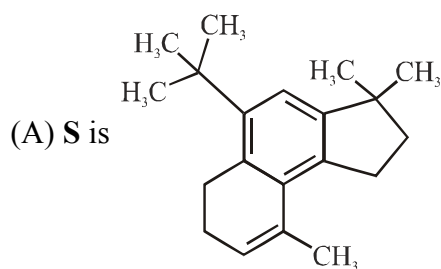

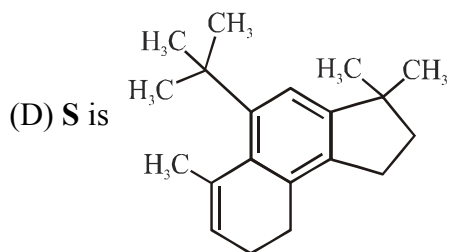
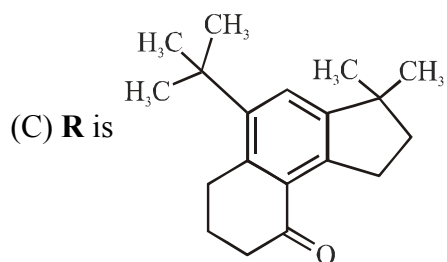

Ans. (B,D)

Sol.

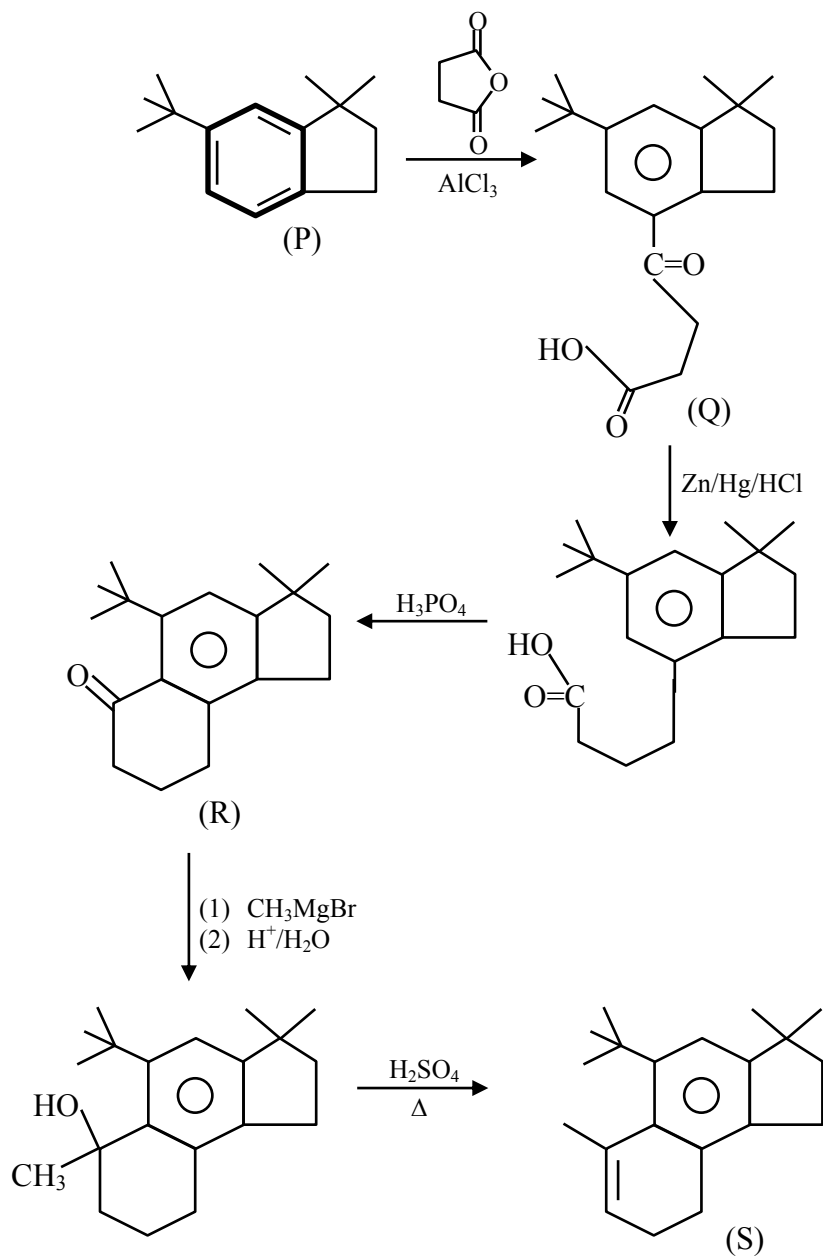

10. Choose the correct statement(s) among the following :

- (A) $[\text{FeCl}_4]^-$ has tetrahedral geometry.
- (B) $[\text{Co}(\text{en})(\text{NH}_3)_2\text{Cl}_2]^+$ has 2 geometrical isomers.
- (C) $[\text{FeCl}_4]^-$ has higher spin-only magnetic moment than $[\text{Co}(\text{en})(\text{NH}_3)_2\text{Cl}_2]^+$.
- (D) The cobalt ion in $[\text{Co}(\text{en})(\text{NH}_3)_2\text{Cl}_2]^+$ has sp^3d^2 hybridization.

Ans. (A,C)

Sol. (A) $[\text{FeCl}_4]^-$

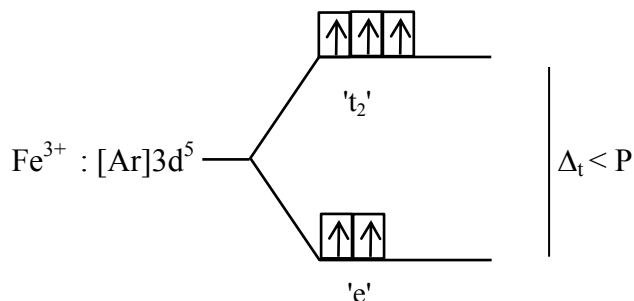

$[\text{FeCl}_4]^-$ is sp^3 hybridised and has tetrahedral geometry with 5 unpaired electrons.

(B) $[\text{Co}(\text{en})(\text{NH}_3)_2\text{Cl}_2]^+$ has three geometrical isomers.

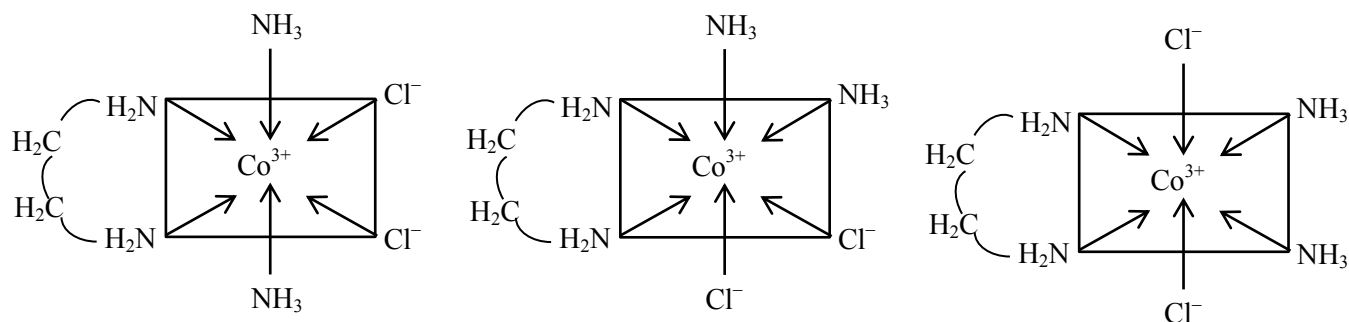

(C) $[\text{FeCl}_4]^-$

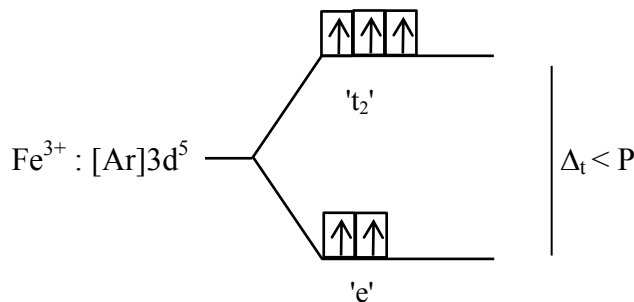

Number of unpaired electrons (n) = 5

$$\begin{aligned}\text{Spin only magnetic moment} &= \sqrt{n(n+2)} \text{ B.M.} \\ &= 5.92 \text{ B.M.}\end{aligned}$$

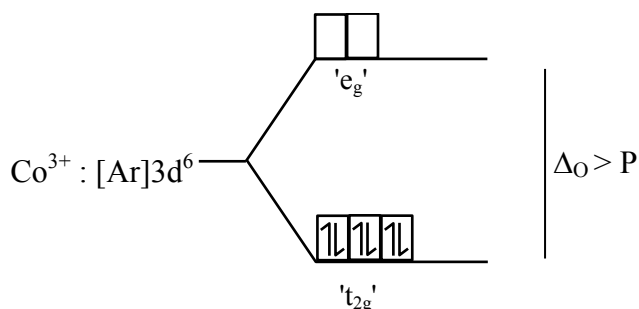

Number of unpaired electrons (n) = 0

$$\begin{aligned}\text{Spin only magnetic moment} &= \sqrt{n(n+2)} \text{ B.M.} \\ &= 0\end{aligned}$$

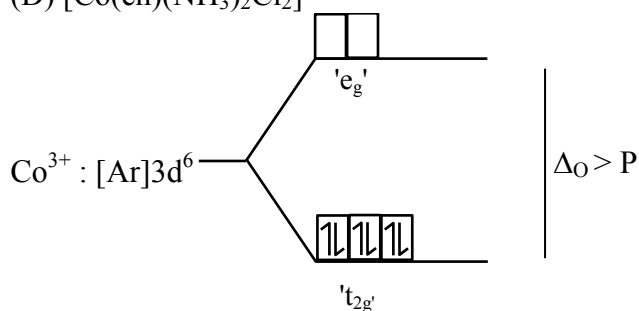
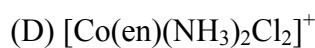

$[\text{Co}(\text{en})(\text{NH}_3)_2\text{Cl}_2]^+$ is d^2sp^3 hybridised and has octahedral geometry with 0 unpaired electron.

11. With respect to hypochlorite, chlorate and perchlorate ions, choose the correct statement(s).
- (A) The hypochlorite ion is the strongest conjugate base.
- (B) The molecular shape of only chlorate ion is influenced by the lone pair of electrons of Cl.
- (C) The hypochlorite and chlorate ions disproportionate to give rise to identical set of ions.
- (D) The hypochlorite ion oxidizes the sulfite ion.

Ans. (A,B,D)

Sol. Hypochlorite ion : ClO^\ominus

Chlorate ion : ClO_3^\ominus

Per chlorate ion : ClO_4^\ominus

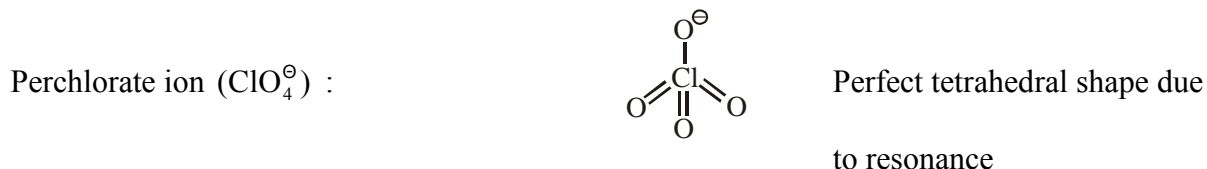
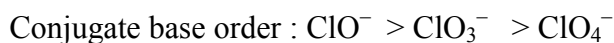
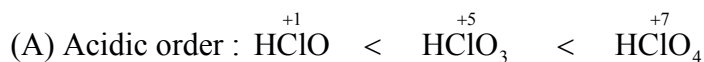

In chlorate ion bond angle changes due to presence of lone pair on chlorine atom. While hypochlorite ion is linear and perchlorate ion is tetrahedral and there is no effect of lone pair on hypochlorite ion.

(C) Disproportionation reaction of

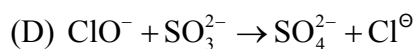
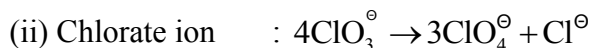
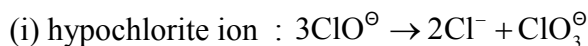

12. The cubic unit cell structure of a compound containing cation M and anion X is shown below. When compared to the anion, the cation has smaller ionic radius. Choose the correct statement(s).

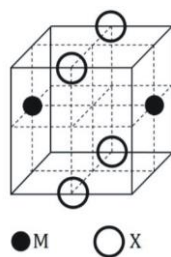

- (A) The empirical formula of the compound is MX.
 (B) The cation M and anion X have different coordination geometries.
 (C) The ratio of M-X bond length to the cubic unit cell edge length is 0.866.
 (D) The ratio of the ionic radii of cation M to anion X is 0.414.

Ans. (A,C)

Sol. (A) $Z_M = 2 \times \frac{1}{2} = 1$

$$Z_X = 4 \times \frac{1}{4} = 1$$

\therefore Empirical formula is MX

(B) Coordinate numbers of both M and X is 8.

(C) Bond length of M – X bond

$$= AB = \sqrt{3} \cdot \frac{a}{2} = 0.866ba$$

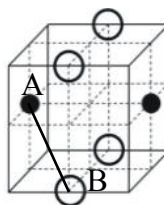

(D) $r_M : r_X = (\sqrt{3} - 1) : 1 = 0.732 : 1.000$

SECTION-3 : (Maximum Marks : 24)

- This section contains **SIX (06)** questions. The answer to each question is a **NUMERICAL VALUE**.
- For each question, enter the correct numerical value of the answer using the mouse and the on-screen virtual numeric keypad in the place designated to enter the answer. If the numerical value has more than two decimal places, **truncate/round-off** the value to **TWO** decimal places.
- Answer to each question will be evaluated according to the following marking scheme :

Full Marks : +4 If **ONLY** the correct numerical value is entered;

Zero Marks : 0 In all other cases.

13. 5.00 mL of 0.10 M oxalic acid solution taken in a conical flask is titrated against NaOH from a burette using phenolphthalein indicator. The volume of NaOH required for the appearance of permanent faint pink color is tabulated below for five experiments. What is the concentration, in molarity, of the NaOH solution ?

Exp. No.	Vol. of NaOH (mL)
1	12.5
2	10.5
3	9.0
4	9.0
5	9.0

Ans. (0.11)

Sol. No. of eq. of oxalic acid = No. of eq. of NaOH

$$\text{or } \frac{5.00 \times 0.10}{1000} \times 2 = \frac{9.0 \times M}{1000} \times 1$$

$$\therefore \text{Molarity of NaOH solution} = \frac{1}{9} = 0.11\text{M}$$

- 14.** Consider the reaction $\text{A} \rightleftharpoons \text{B}$ at 1000 K. At time t' , the temperature of the system was increased to 2000 K and the system was allowed to reach equilibrium. Throughout this experiment the partial pressure of A was maintained at 1 bar. Given below is the plot of the partial pressure of B with time. What is the ratio of the standard Gibbs energy of the reaction at 1000 K to that at 2000 K?

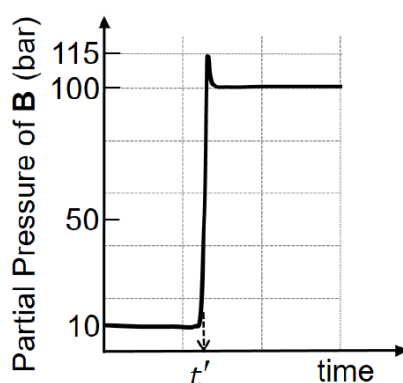

Ans. (0.25)

Sol. $K_{\text{eq}} = \frac{[\text{B}]}{[\text{A}]}$

$$K_{1000} = \frac{10}{1} = 10 \quad \text{and} \quad K_{2000} = \frac{100}{1} = 100$$

$$\text{Now, } \frac{\Delta G_{1000}^0}{\Delta G_{2000}^0} = \frac{(-RT \ln K_{\text{eq}})_{1000}}{(-RT \ln K_{\text{eq}})_{2000}} = \frac{1000 \times \ln 10}{2000 \times \ln 100} = 0.25$$

- 15.** Consider a 70% efficient hydrogen-oxygen fuel cell working under standard conditions at 1 bar and 298 K. Its cell reaction is

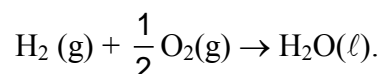

The work derived from the cell on the consumption of 1.0×10^{-3} mol of $\text{H}_2(\text{g})$ is used to compress 1.00 mol of a monoatomic ideal gas in a thermally insulated container. What is the change in the temperature (in K) of the ideal gas?

The standard reduction potentials for the two half-cells are given below.

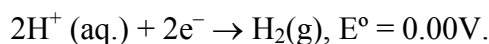
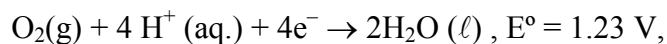

Use $F = 96500 \text{ C mol}^{-1}$, $R = 8.314 \text{ J mol}^{-1}\text{K}^{-1}$

Ans. (13.32)

Sol. $E_{\text{cell}}^0 = 1.23 - 0.00 = 1.23 \text{ V}$

$$\Delta G_{\text{cell}}^0 = -nF E_{\text{cell}}^0 = -2 \times 96500 \times 1.23 \text{ J}$$

\therefore Work derived from this fuel cell

$$= \frac{70}{100} \times (-\Delta G_{\text{cell}}^0) \times 10^{-3} = x \text{ J}$$

Since insulated vessel, hence $q = 0$

From equation, for monoatomic gas,

$$w = \Delta U \quad \Rightarrow \quad x = nC_{v,m}\Delta T \left\{ C_{v,m} = \frac{3R}{2} \right\}$$

$$\text{or, } \frac{70}{100} \times (2 \times 96500 \times 1.23) \times 10^{-3} = 1 \times \frac{3}{2} \times 8.314 \times \Delta T$$

$$\therefore \Delta T = 13.32$$

- 16.** Aluminium reacts with sulfuric acid to form aluminium sulfate and hydrogen. What is the volume of hydrogen gas in liters (L) produced at 300 K and 1.0 atm pressure, when 5.4 g of aluminium and 50.0 mL of 5.0 M sulfuric acid are combined for the reaction ?

(Use molar mass of aluminium as 27.0 g mol^{-1} , $R = 0.082 \text{ atm L mol}^{-1} \text{ K}^{-1}$)

Ans. (6.15)

Sol. $2\text{Al} + 3\text{H}_2\text{SO}_4 \longrightarrow \text{Al}_2(\text{SO}_4)_3 + 3\text{H}_2$

$$\text{Moles of Al taken} = \frac{5.4}{27} = 0.2$$

$$\text{moles of H}_2\text{SO}_4 \text{ taken} = \frac{50 \times 5.0}{1000} = 0.25$$

As $\frac{0.2}{2} > \frac{0.25}{3}$, H_2SO_4 is limiting reagent

$$\text{Now, moles of H}_2 \text{ formed} = \frac{3}{3} \times 0.25 = 0.25$$

$$\begin{aligned} \therefore \text{Volume of H}_2 \text{ gas formed} &= \frac{nRT}{P} \\ &= \frac{0.25 \times 0.082 \times 300}{1} = 6.15 \text{ L} \end{aligned}$$

17. ${}_{92}^{238}\text{U}$ is known to undergo radioactive decay to form ${}_{82}^{206}\text{Pb}$ by emitting alpha and beta particles. A rock initially contained 68×10^{-6} g of ${}_{92}^{238}\text{U}$. If the number of alpha particles that it would emit during its radioactive decay of ${}_{92}^{238}\text{U}$ to ${}_{82}^{206}\text{Pb}$ in three half-lives is $Z \times 10^{18}$, then what is the value of Z ?

Ans. (1.20)

Sol. Initial moles of $\text{U}^{238} = \frac{68 \times 10^{-6}}{238} = x$

$$\text{Moles of } \text{U}^{238} \text{ decayed in three half-lives} = \frac{7}{8}x$$

In decay from U^{238} to Pb^{206} , each U^{238} atom decays and produces 8 α -particles and hence, total number of α -particles emitted out

$$= \left(\frac{7}{8}x\right) \times 8 \times N_A$$

$$= 7 \times \frac{68 \times 10^{-6}}{238} \times 6.022 \times 10^{23}$$

$$= 1.204 \times 10^{18}$$

18. In the following reaction, compound **Q** is obtained from compound **P** via an ionic intermediate

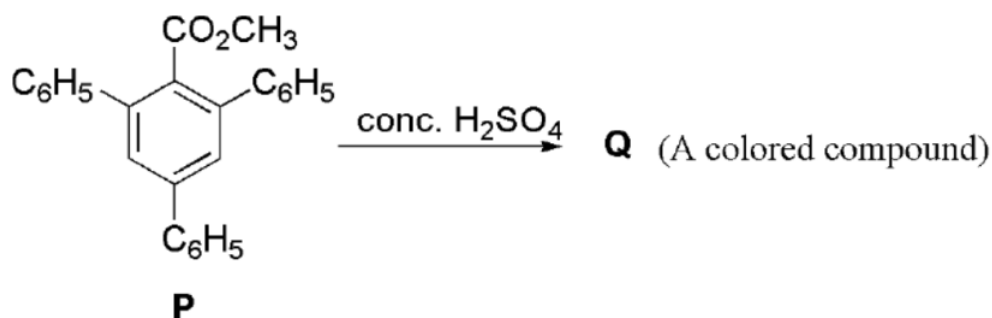

What is the degree of unsaturation of **Q**?

Ans. (18.00)

Sol.

