

# FINAL JEE(Advanced) EXAMINATION – 2023

(Held On Sunday 04<sup>th</sup> June, 2023)

PAPER-2

TEST PAPER WITH SOLUTION

## PHYSICS

### SECTION-1 : (Maximum Marks : 12)

- This section contains **FOUR (04)** questions.
- Each question has **FOUR** options (A), (B), (C) and (D). **ONLY ONE** of these four options is the correct answer.
- For each question, choose the option corresponding to the correct answer.
- Answer to each question will be evaluated according to the following marking scheme:

*Full Marks* : +3 If **ONLY** the correct option is chosen;

*Zero Marks* : 0 If none of the options is chosen (i.e. the question is unanswered);

*Negative Marks* : -1 In all other cases.

1. An electric dipole is formed by two charges  $+q$  and  $-q$  located in  $xy$ -plane at  $(0, 2)$  mm and  $(0, -2)$  mm, respectively, as shown in the figure. The electric potential at point  $P(100, 100)$  mm due to the dipole is  $V_0$ . The charges  $+q$  and  $-q$  are then moved to the points  $(-1, 2)$  mm and  $(1, -2)$  mm, respectively. What is the value of electric potential at  $P$  due to the new dipole ?

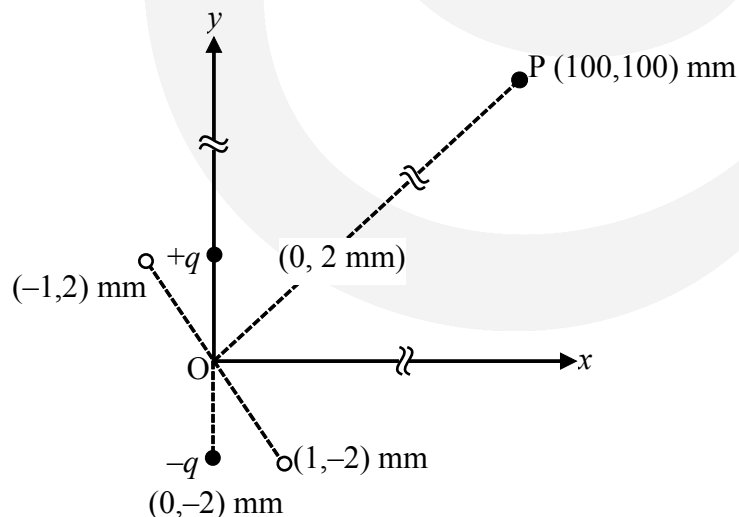

(A)  $V_0/4$

(B)  $V_0/2$

(C)  $V_0/\sqrt{2}$

(D)  $3V_0/4$

Ans. (B)

Sol.

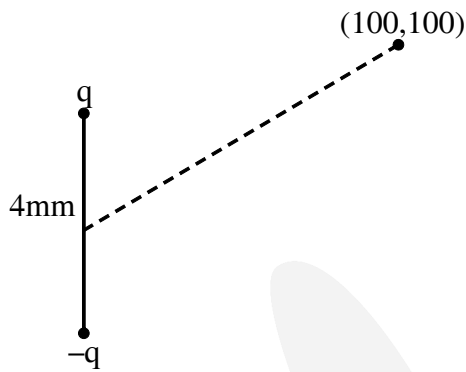

$$P_1 = q(4)$$

$$\vec{P}_1 = P_1 \hat{j}$$

$$\vec{r} = 100(\hat{i} + \hat{j})\text{mm}$$

$$v_0 = \frac{K P_1 \cdot \vec{r}}{r^3} = \frac{K(100P_1)}{(100\sqrt{2})^3}$$

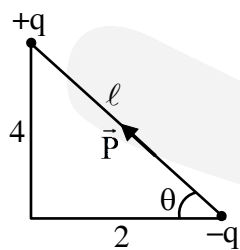

$$\tan \theta = 2$$

$$\vec{P}_2 = P_2 [-\cos \theta \hat{i} + \sin \theta \hat{j}]$$

$$\vec{r} = 100(\hat{i} + \hat{j})\text{mm}$$

$$P_2 = q\ell$$

$$v = \frac{K \vec{P}_2 \cdot \vec{r}}{r^3}$$

$$v = \frac{K(100P_2) - (-\cos \theta + \sin \theta)}{(100\sqrt{2})^3}$$

$$\frac{v_0 P_2}{P_1} = (-\cos \theta + \sin \theta)$$

$$v = v_0 \frac{q\ell}{q(4)} [-\cos \theta + \sin \theta]$$

$$= \frac{v_0}{4} [-2 + 4] = \frac{v_0}{2}$$

2. Young's modulus of elasticity  $Y$  is expressed in terms of three derived quantities, namely, the gravitational constant  $G$ , Planck's constant  $h$  and the speed of light  $c$ , as  $Y = c^\alpha h^\beta G^\gamma$ . Which of the following is the correct option ?

(A)  $\alpha = 7, \beta = -1, \gamma = -2$

(B)  $\alpha = -7, \beta = -1, \gamma = -2$

(C)  $\alpha = 7, \beta = -1, \gamma = 2$

(D)  $\alpha = -7, \beta = 1, \gamma = -2$

**Ans. (A)**

**Sol.**  $Y = c^\alpha h^\beta G^\gamma$

$$ML^{-1}T^{-2} = (LT^{-1})^\alpha (ML^2T^{-1})^\beta (M^{-1}L^3T^{-2})^\gamma$$

$$1 = \beta - \gamma \quad \dots(1)$$

$$-1 = \alpha + 2\beta + 3\gamma \quad \dots(2)$$

$$-2 = -\alpha - \beta - 2\gamma \quad \dots(3)$$

$$\underline{-3 = \beta + \gamma}$$

$$\underline{1 = \beta - \gamma}$$

$$-2 = 2\beta \Rightarrow \beta = -1, \gamma = -2$$

$$-1 = \alpha - 2 - 6 \quad \therefore \alpha = 7$$

3. A particle of mass  $m$  is moving in the  $xy$ -plane such that its velocity at a point  $(x, y)$  is given as  $\vec{v} = \alpha(y\hat{x} + 2x\hat{y})$ , where  $\alpha$  is a non-zero constant. What is the force  $\vec{F}$  acting on the particle ?

(A)  $\vec{F} = 2m\alpha^2(x\hat{x} + y\hat{y})$

(B)  $\vec{F} = m\alpha^2(y\hat{x} + 2x\hat{y})$

(C)  $\vec{F} = 2m\alpha^2(y\hat{x} + x\hat{y})$

(D)  $\vec{F} = m\alpha^2(x\hat{x} + 2y\hat{y})$

**Ans. (A)**

**Sol.**  $\vec{v} = \alpha(y\hat{x} + 2x\hat{y})$

$$v_x = \alpha y$$

$$v_y = 2\alpha x$$

$$\frac{dv_x}{dt} = \alpha \frac{dy}{dt} = 2\alpha^2 x \quad \frac{dv_y}{dt} = 2\alpha v_x = 2\alpha^2 y$$

$$\therefore \vec{F} = m\vec{a} = 2m\alpha^2(x\hat{x} + y\hat{y})$$

4. An ideal gas is in thermodynamic equilibrium. The number of degrees of freedom of a molecule of the gas is  $n$ . The internal energy of one mole of the gas is  $U_n$  and the speed of sound in the gas is  $v_n$ . At a fixed temperature and pressure, which of the following is the correct option ?

(A)  $v_3 < v_6$  and  $U_3 > U_6$

(B)  $v_5 > v_3$  and  $U_3 > U_5$

(C)  $v_5 > v_7$  and  $U_5 < U_7$

(D)  $v_6 < v_7$  and  $U_6 < U_7$

**Ans. (C)**

**Sol.**  $U = \frac{1}{2} f n R T = \frac{f R T}{2}$

 $\therefore$  A and B are wrong.

$$v_{\text{sound}} = \sqrt{\frac{\gamma R T}{M}} = \sqrt{\left(\frac{2}{f} + 1\right) \frac{R T}{M}}$$

 $\Rightarrow$  more 'f', less 'v'

$$\therefore v_5 > v_7$$

## SECTION-2 : (Maximum Marks : 12)

- This section contains **THREE (03)** questions.
- Each question has **FOUR** options (A), (B), (C) and (D). **ONE OR MORE THAN ONE** of these four option(s) is (are) correct answer(s).
- For each question, choose the option(s) corresponding to (all) the correct answer(s).
- Answer to each question will be evaluated according to the following marking scheme:
 

<i>Full Marks</i>	: +4	<b>ONLY</b> if (all) the correct option(s) is(are) chosen;
<i>Partial Marks</i>	: +3	If all the four options are correct but <b>ONLY</b> three options are chosen;
<i>Partial Marks</i>	: +2	If three or more options are correct but <b>ONLY</b> two options are chosen, both of which are correct;
<i>Partial Marks</i>	: +1	If two or more options are correct but <b>ONLY</b> one option is chosen and it is a correct option;
<i>Zero Marks</i>	: 0	If unanswered;
<i>Negative Marks</i>	: -2	In all other cases.
- For example, in a question, if (A), (B) and (D) are the **ONLY** three options corresponding to correct answers, then
  - choosing **ONLY** (A), (B) and (D) will get +4 marks;
  - choosing **ONLY** (A) and (B) will get +2 marks;
  - choosing **ONLY** (A) and (D) will get +2 marks;
  - choosing **ONLY** (B) and (D) will get +2 marks;
  - choosing **ONLY** (A) will get +1 mark;
  - choosing **ONLY** (B) will get +1 mark;
  - choosing **ONLY** (D) will get +1 mark;
  - choosing no option(s) (i.e. the question is unanswered) will get 0 marks and
  - choosing any other option(s) will get -2 marks.

5. A monochromatic light wave is incident normally on a glass slab of thickness  $d$ , as shown in the figure. The refractive index of the slab increases linearly from  $n_1$  to  $n_2$  over the height  $h$ . Which of the following statement(s) is (are) true about the light wave emerging out of the slab ?

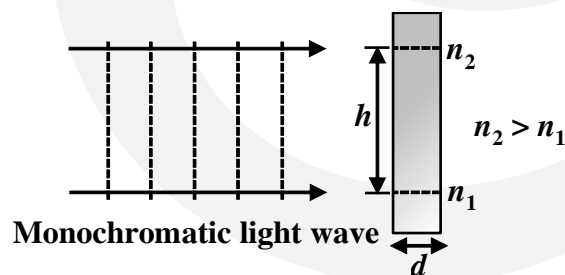

(A) It will deflect up by an angle  $\tan^{-1} \left[ \frac{(n_2^2 - n_1^2)d}{2h} \right]$

(B) It will deflect up by an angle  $\tan^{-1} \left[ \frac{(n_2 - n_1)d}{h} \right]$

(C) It will not deflect.

(D) The deflection angle depends only on  $(n_2 - n_1)$  and not on the individual values of  $n_1$  and  $n_2$ .

Ans. (B, D)

Sol.

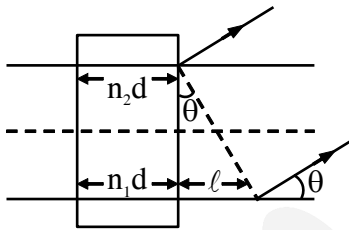

$$n_1 d + l = n_2 d$$

$$\tan \theta = \frac{l}{h} = \frac{(n_2 - n_1)d}{h}$$

6. An annular disk of mass  $M$ , inner radius  $a$  and outer radius  $b$  is placed on a horizontal surface with coefficient of friction  $\mu$ , as shown in the figure. At some time, an impulse  $J_0 \hat{x}$  is applied at a height  $h$  above the center of the disk. If  $h = h_m$  then the disk rolls without slipping along the  $x$ -axis. Which of the following statement(s) is(are) correct ?

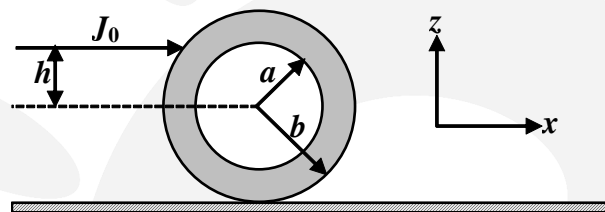

- (A) For  $\mu \neq 0$  and  $a \rightarrow 0$ ,  $h_m = b/2$   
 (B) For  $\mu \neq 0$  and  $a \rightarrow b$ ,  $h_m = b$   
 (C) For  $h = h_m$ , the initial angular velocity does **not** depend on the inner radius  $a$ .  
 (D) For  $\mu = 0$  and  $h = 0$ , the wheel always slides without rolling.

Ans. (A,B,C,D)

Sol.  $J_0 = mv \dots(1)$

$$J_0 h_m = I_c \omega \dots(2)$$

$$v = \omega R \dots(3)$$

$$\Rightarrow h_m = \frac{I_c}{mR}$$

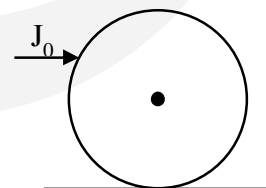

(A) If  $a = 0$   $I_c = \frac{1}{2}mb^2$  &  $R = b \therefore h_m = \frac{b}{2}$

(B) If  $a = b$   $I_c = mb^2$  &  $R = b \therefore h_m = b$

(C)  $v = \frac{J_0}{m} \Rightarrow 100 = \frac{V}{R} = \frac{J_0}{mR}$

(D) Force is acting on COM  $\therefore$  No rotation.

7. The electric field associated with an electromagnetic wave propagating in a dielectric medium is given by  $\vec{E} = 30(2\hat{x} + \hat{y}) \sin \left[ 2\pi \left( 5 \times 10^{14} t - \frac{10^7}{3} z \right) \right] \text{ V m}^{-1}$ . Which of the following option(s) is(are) correct?

[Given: The speed of light in vacuum,  $c = 3 \times 10^8 \text{ ms}^{-1}$ ]

(A)  $B_x = -2 \times 10^{-7} \sin \left[ 2\pi \left( 5 \times 10^{14} t - \frac{10^7}{3} z \right) \right] \text{ Wbm}^{-2}$ .

(B)  $B_y = 2 \times 10^{-7} \sin \left[ 2\pi \left( 5 \times 10^{14} t - \frac{10^7}{3} z \right) \right] \text{ Wbm}^{-2}$

(C) The wave is polarized in the  $xy$ -plane with polarization angle  $30^\circ$  with respect to the  $x$ -axis.

(D) The refractive index of the medium is 2.

Ans. (A, D)

Sol.

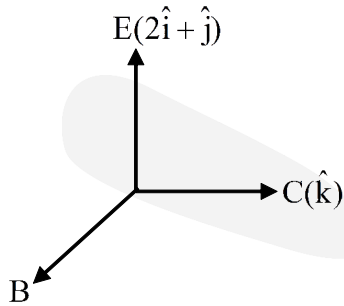

$$C_{\text{medium}} = \frac{5 \times 10^{14}}{10^7 / 3} = 1.5 \times 10^8 \text{ m/s} \quad \therefore \mu = 2$$

$$C_{\text{medium}} = \frac{E}{B} \Rightarrow B = \frac{E}{C_m} = \frac{30\sqrt{5}}{1.5 \times 10^8} = 2\sqrt{5} \times 10^{-7}$$

$$\vec{B}_{\text{direction}} \equiv \hat{k} \times (2\hat{i} + \hat{j}) \equiv \frac{2\hat{j} - \hat{i}}{\sqrt{5}}$$

$$\therefore \vec{B} = 2 \times 10^{-7} (-\hat{i} + 2\hat{j}) \sin \left[ 2\pi \left( 5 \times 10^{14} t - \frac{10^7}{3} z \right) \right]$$

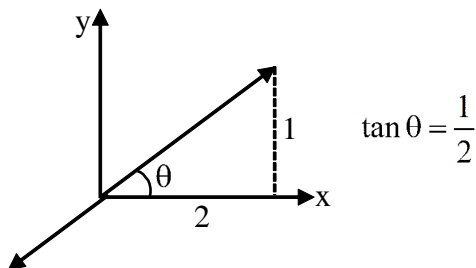

**SECTION-3 : (Maximum Marks : 24)**

- This section contains **SIX (06)** questions.
- The answer to each question is a **NON-NEGATIVE INTEGER**.
- For each question, enter the correct integer corresponding to the answer using the mouse and the on-screen virtual numeric keypad in the place designated to enter the answer.
- Answer to each question will be evaluated according to the following marking scheme:  
*Full Marks* : +4 If **ONLY** the correct integer is entered;  
*Zero Marks* : 0 In all other cases

8. A thin circular coin of mass 5 gm and radius  $4/3$  cm is initially in a horizontal  $xy$ -plane. The coin is tossed vertically up (+ $z$  direction) by applying an impulse of  $\sqrt{\frac{\pi}{2}} \times 10^{-2}$  N-s at a distance  $2/3$  cm from its center. The coin spins about its diameter and moves along the + $z$  direction. By the time the coin reaches back to its initial position, it completes  $n$  rotations. The value of  $n$  is \_\_\_\_\_.  
 [Given: The acceleration due to gravity  $g = 10 \text{ ms}^{-2}$ ]

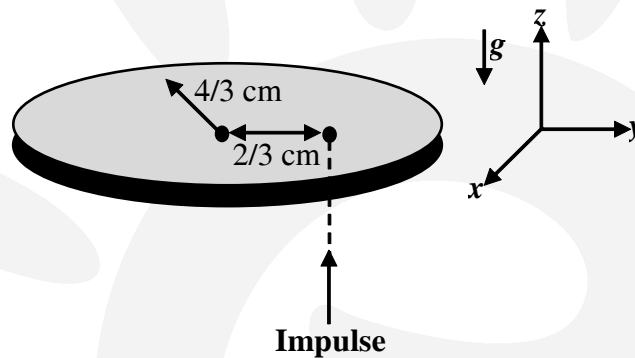

Ans. (30)

Sol.

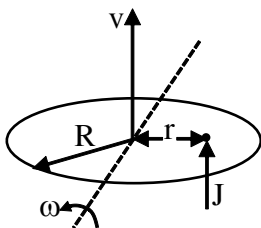

$$J = mv \dots\dots(1)$$

$$Jr = I_c \omega \dots\dots(2)$$

$$J_C = \frac{1}{4} mR^2 \dots\dots(3)$$

$$t = \frac{2v}{g} \dots\dots(4)$$

$$\theta = 2\pi N = \omega t \dots\dots(5) \quad \therefore N = 30$$

9. A rectangular conducting loop of length 4 cm and width 2 cm is in the  $xy$ -plane, as shown in the figure. It is being moved away from a thin and long conducting wire along the direction  $\frac{\sqrt{3}}{2}\hat{x} + \frac{1}{2}\hat{y}$  with a constant speed  $v$ . The wire is carrying a steady current  $I = 10$  A in the positive  $x$ -direction. A current of  $10 \mu\text{A}$  flows through the loop when it is at a distance  $d = 4$  cm from the wire. If the resistance of the loop is  $0.1 \Omega$ , then the value of  $v$  is \_\_\_\_\_  $\text{ms}^{-1}$ .

[Given: The permeability of free space  $\mu_0 = 4\pi \times 10^{-7} \text{NA}^{-2}$ ]

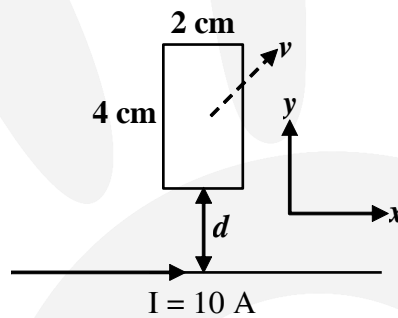

Ans. (4)

Sol.  $R = 0.1 \Omega$

$$\varepsilon = (B_1 - B_2)bv_y$$

$$i = \frac{\varepsilon}{R} = \frac{\mu_0 I}{2\pi R} \left( \frac{1}{d} - \frac{1}{d+a} \right) bv_y$$

$$\Rightarrow 10^{-5} = \frac{2 \times 10^{-7} \times 10}{0.1} \left[ \frac{1}{4} - \frac{1}{8} \right] \times 2 \cdot v_y$$

$$\therefore v_y = 2$$

$$\tan \theta = \frac{v_y}{v_x} = \frac{1}{\sqrt{3}}$$

$$\therefore v_x = 2\sqrt{3}$$

$$\therefore v = \sqrt{v_x^2 + v_y^2} = 4$$

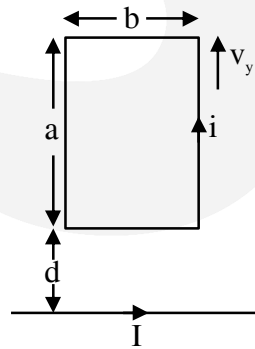

$\theta$



10. A string of length 1 m and mass  $2 \times 10^{-5}$  kg is under tension T. when the string vibrates, two successive harmonics are found to occur at frequencies 750 Hz and 1000 Hz. The value of tension T is \_\_\_\_\_ Newton.

Ans. (5)

Sol.  $f = \frac{P}{2\ell} \sqrt{\frac{T}{\mu}}$

$$750 = \frac{P}{2} \sqrt{\frac{T}{\mu}} \dots\dots(1)$$

$$1000 = \frac{P+1}{2} \sqrt{\frac{T}{\mu}} \dots\dots(2)$$

$$\frac{4}{3} = \frac{P+1}{P} \quad \therefore P = 3$$

$$\Rightarrow 1000 = \frac{4}{2} \sqrt{\frac{T}{2 \times 10^{-5}}} \quad \therefore T = 5\text{N}$$

11. An incompressible liquid is kept in a container having a weightless piston with a hole. A capillary tube of inner radius 0.1 mm is dipped vertically into the liquid through the airtight piston hole, as shown in the figure. The air in the container is isothermally compressed from its original volume  $V_0$  to  $\frac{100}{101}V_0$  with the movable piston. Considering air as an ideal gas, the height ( $h$ ) of the liquid column in the capillary above the liquid level in cm is \_\_\_\_\_.

[Given: Surface tension of the liquid is  $0.075 \text{ Nm}^{-1}$ , atmospheric pressure is  $10^5 \text{ N m}^{-2}$ , acceleration due to gravity ( $g$ ) is  $10 \text{ m s}^{-2}$ , density of the liquid is  $10^3 \text{ kg m}^{-3}$  and contact angle of capillary surface with the liquid is zero]

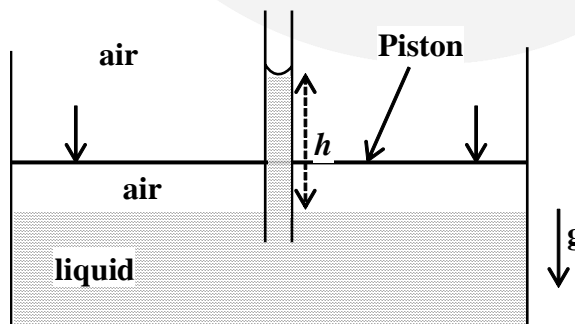

Ans. (25)

Sol.

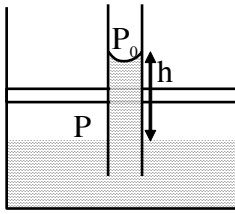

$$h_0 = \frac{2T \cos \theta}{\rho g r} = \frac{2 \times 0.075 \times 1}{10^3 \times 10 \times 10^{-4}} = 15 \text{ cm}$$

$$P_0 V_0 = P \frac{100 V_0}{101} \Rightarrow P = \frac{101}{100} P_0$$

$$P_0 - \frac{2T \cos \theta}{r} + \rho g h = P = \frac{101}{100} P_0$$

$$\Rightarrow -\rho g h_0 + \rho g h = \frac{P_0}{100}$$

$$\Rightarrow h = h_0 + \frac{P_0}{100 \rho g}$$

$$= 15 \text{ cm} + \frac{10^5}{100 \times 10^3 \times 10} = 25 \text{ cm}$$

12. In a radioactive decay process, the activity is defined as  $A = -\frac{dN}{dt}$ , where  $N(t)$  is the number of radioactive nuclei at time  $t$ . Two radioactive sources,  $S_1$  and  $S_2$  have same activity at time  $t = 0$ . At a later time, the activities of  $S_1$  and  $S_2$  are  $A_1$  and  $A_2$ , respectively. When  $S_1$  and  $S_2$  have just completed their 3<sup>rd</sup> and 7<sup>th</sup> half-lives, respectively, the ratio  $A_1/A_2$  is \_\_\_\_\_.

Ans. (16)

	$S_1$	$S_2$
Sol. $t = 0$	$A_0$	$A_0$
$t = \tau$	$A_1$	$A_2$

$$\frac{A_1}{A_2} = \frac{A_0 (0.5)^{t/(t_{1/2})_1}}{A_0 (0.5)^{t/(t_{1/2})_2}} = \frac{(0.5)^3}{(0.5)^7} = 2^4 = 16$$

13. One mole of an ideal gas undergoes two different cyclic processes I and II, as shown in the  $P$ - $V$  diagrams below. In cycle I, processes  $a$ ,  $b$ ,  $c$  and  $d$  are isobaric, isothermal, isobaric and isochoric, respectively. In cycle II, processes  $a'$ ,  $b'$ ,  $c'$  and  $d'$  are isothermal, isochoric, isobaric and isochoric, respectively. The total work done during cycle I is  $W_I$  and that during cycle II is  $W_{II}$ . The ratio  $W_I/W_{II}$  is \_\_\_\_\_.

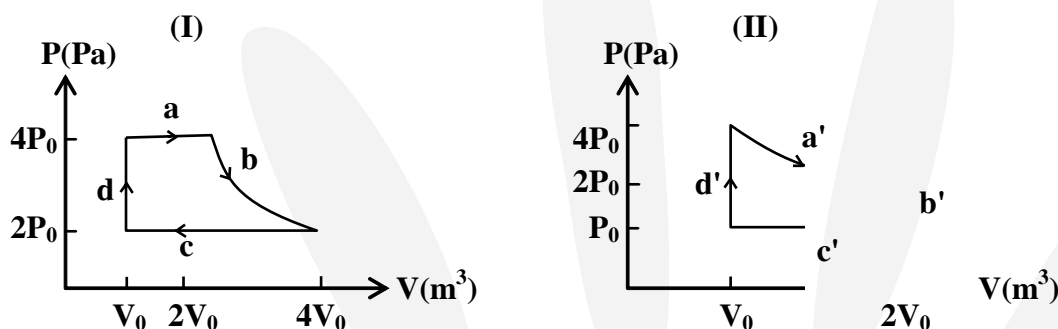

Ans. (2)

Sol. 
$$\frac{W_I}{W_{II}} = \frac{4P_0V_0 + 8P_0V_0\ln 2 - 6P_0V_0 - 0}{4P_0V_0\ln 2 - 0 - P_0V_0 + 0}$$

$$= \frac{8\ln 2 - 2}{4\ln 2 - 1} = 2$$

**SECTION-4 : (Maximum Marks : 12)**

- This section contains **TWO (02)** paragraphs.
- Based on each paragraph, there are **TWO (02)** questions.
- The answer to each question is a **NUMERICAL VALUE**.
- For each question, enter the correct numerical value of the answer using the mouse and the onscreen virtual numeric keypad in the place designated to enter the answer.
- If the numerical value has more than two decimal places, **truncate/round-off** the value to **TWO** decimal places.
- Answer to each question will be evaluated according to the following marking scheme:

*Full Marks* : +3 If **ONLY** the correct numerical value is entered in the designated place;

*Zero Marks* : 0 In all other cases.

## PARAGRAPH-I

$S_1$  and  $S_2$  are two identical sound sources of frequency 656 Hz. The source  $S_1$  is located at  $O$  and  $S_2$  moves anti-clockwise with a uniform speed  $4\sqrt{2} \text{ ms}^{-1}$  on a circular path around  $O$ , as shown in the figure. There are three points  $P$ ,  $Q$  and  $R$  on this path such that  $P$  and  $R$  are diametrically opposite while  $Q$  is equidistant from them. A sound detector is placed at point  $P$ . The source  $S_2$  can move along direction  $OP$ .

[Given: The speed of sound in air is  $324 \text{ ms}^{-1}$ ]

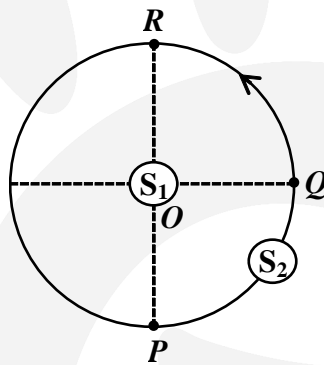

14. When only  $S_2$  is emitting sound and it is at  $Q$ , the frequency of sound measured by the detector in Hz is \_\_\_\_\_.

Ans. (648)

Sol.

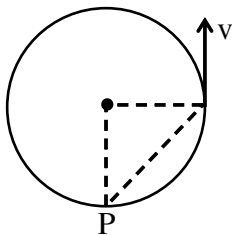

$$f' = \frac{C}{C + v \cos 45^\circ} f$$

$$= \frac{324}{324 + 4\sqrt{2} \times \frac{1}{\sqrt{2}}} \times 656 = 648 \text{ Hz}$$

## PARAGRAPH-I

$S_1$  and  $S_2$  are two identical sound sources of frequency 656 Hz. The source  $S_1$  is located at  $O$  and  $S_2$  moves anti-clockwise with a uniform speed  $4\sqrt{2} \text{ ms}^{-1}$  on a circular path around  $O$ , as shown in the figure. There are three points  $P$ ,  $Q$  and  $R$  on this path such that  $P$  and  $R$  are diametrically opposite while  $Q$  is equidistant from them. A sound detector is placed at point  $P$ . The source  $S_1$  can move along direction  $OP$ .

[Given: The speed of sound in air is  $324 \text{ ms}^{-1}$ ]

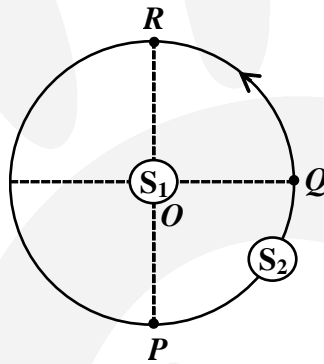

15. Consider both sources emitting sound. When  $S_2$  is at  $R$  and  $S_1$  approaches the detector with a speed  $4 \text{ ms}^{-1}$ , the beat frequency measured by the detector is \_\_\_\_\_ Hz.

**Ans. (8.2)**

**Sol.**  $f_{P \text{ from } S_2} = 656 \text{ Hz}$

$$f_{P \text{ from } S_1} = \frac{C}{C - V} f = \frac{656 \times 324}{324 - 4} = 664.2$$

$$\Delta f = 664.2 - 656 = 8.2 \text{ Hz}$$

## PARAGRAPH-II

A cylindrical furnace has height ( $H$ ) and diameter ( $D$ ) both 1 m. It is maintained at temperature 360 K. The air gets heated inside the furnace at constant pressure  $P_a$  and its temperature becomes  $T = 360$  K. The hot air with density  $\rho$  rises up a vertical chimney of diameter  $d = 0.1$  m and height  $h = 9$  m above the furnace and exits the chimney (see the figure). As a result, atmospheric air of density  $\rho_a = 1.2 \text{ kg m}^{-3}$ , pressure  $P_a$  and temperature  $T_a = 300$  K enters the furnace. Assume air as an ideal gas, neglect the variations in  $\rho$  and  $T$  inside the chimney and the furnace. Also ignore the viscous effects.

[Given: The acceleration due to gravity  $g = 10 \text{ ms}^{-2}$  and  $\pi = 3.14$ ]

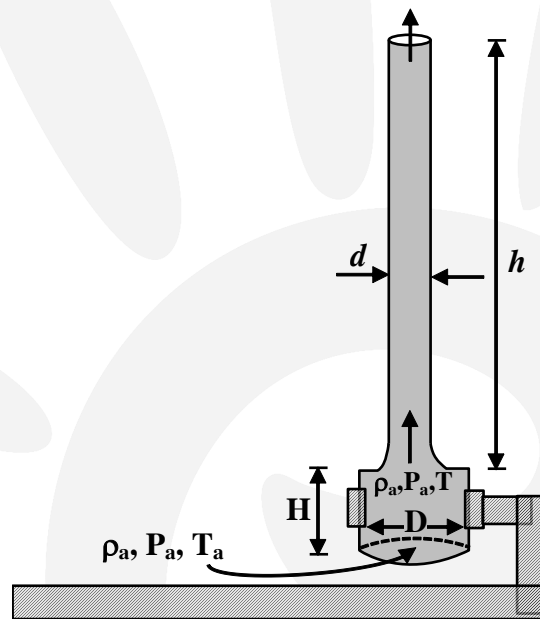

16. Considering the air flow to be streamline, the steady mass flow rate of air exiting the chimney is \_\_\_\_\_  $\text{gm s}^{-1}$ .

Ans. (60.80, 60.81)

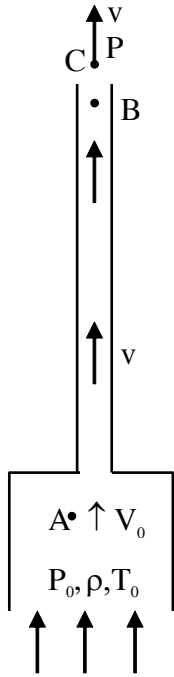

Sol.

$$\rho_0 T_0 = \rho T$$

$$\Rightarrow 1.2 \times 300 = \rho(360) \therefore \rho = 1$$

Between A & B

$$P_0 + \frac{1}{2} \rho V_0^2 = P + \frac{1}{2} \rho V^2 + \rho gh \dots\dots(1)$$

$$\frac{\pi D^2}{4} V_0 = \frac{\pi d^2}{4} V \dots\dots(2)$$

Between B & C

$$P + \frac{1}{2} \rho V^2 = P_0 - \rho_0 g(H + h) + \frac{1}{2} \rho V^2 \dots\dots(3)$$

from (1) & (2) :

$$\Rightarrow P_0 + \frac{1}{2} \rho \left( V \frac{d^2}{D^2} \right)^2 = P + \frac{1}{2} \rho V^2 + \rho gh$$

$$\Rightarrow \rho_0 g(H + h) = \frac{1}{2} \rho V^2 \left[ 1 - \frac{d^4}{D^4} \right] + \rho gh$$

$$\Rightarrow V^2 \approx \frac{2\rho_0}{\rho} g(H + h) - 2gh$$

$$= 2 \times 1.2 \times 10 \times 10 - 2 \times 10 \times 9$$

$$= 240 - 180 = 60 \therefore V = \sqrt{60} \text{ m/s}$$

$$Q_m = \rho \frac{\pi d^2}{4} V = 1 \times \frac{\pi}{4} \times 10^{-2} \times \sqrt{60} \approx 60.80$$

Ans. 60.80 to 60.81

## PARAGRAPH-II

A cylindrical furnace has height ( $H$ ) and diameter ( $D$ ) both 1 m. It is maintained at temperature 360 K. The air gets heated inside the furnace at constant pressure  $P_a$  and its temperature becomes  $T = 360$  K. The hot air with density  $\rho$  rises up a vertical chimney of diameter  $d = 0.1$  m and height  $h = 9$  m above the furnace and exits the chimney (see the figure). As a result, atmospheric air of density  $\rho_a = 1.2 \text{ kg m}^{-3}$ , pressure  $P_a$  and temperature  $T_a = 300$  K enters the furnace. Assume air as an ideal gas, neglect the variations in  $\rho$  and  $T$  inside the chimney and the furnace. Also ignore the viscous effects.

[Given: The acceleration due to gravity  $g = 10 \text{ ms}^{-2}$  and  $\pi = 3.14$ ]

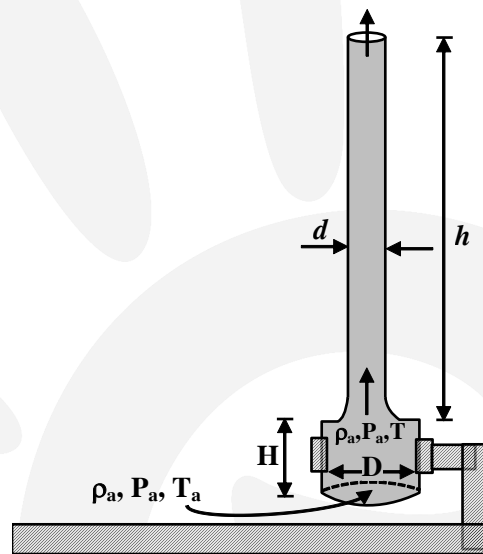



17. When the chimney is closed using a cap at the top, a pressure difference  $\Delta P$  develops between the top and the bottom surfaces of the cap. If the changes in the temperature and density of the hot air, due to the stoppage of air flow, are negligible then the value of  $\Delta P$  is \_\_\_\_\_  $\text{Nm}^{-2}$ .

Ans. (30)

Sol.

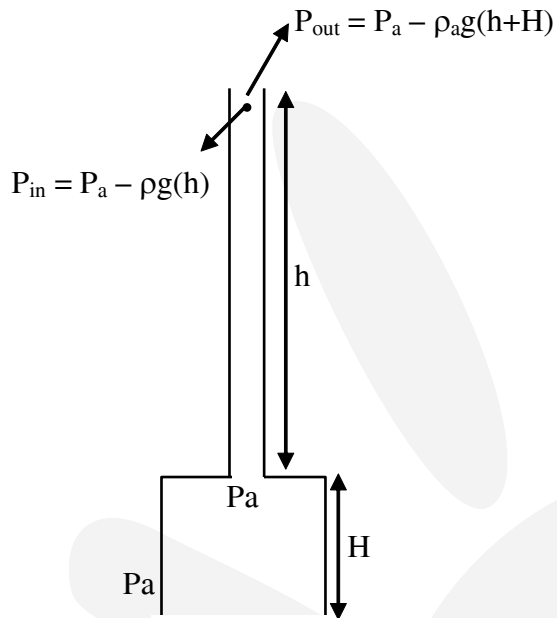

$$P = \text{constant}$$

$$\Rightarrow \rho_a T_a = \rho T$$

$$1.2 \times 300 = \rho \times 360$$

$$\rho = 1 \text{ kg/m}^3$$

$$\Delta P = \rho_a g (h + H) - \rho g h$$

$$= 1.2 \times 10 \times 10 - 1 \times 10 \times 9$$

$$= 120 - 90 = 30 \text{ N/m}^2$$