

FINAL JEE-MAIN EXAMINATION - JULY, 2022
Held On Tuesday 26 July,2022
TIME :3:00 PM to 06:00 PM

SECTION-A

1. Two projectiles are thrown with same initial velocity making an angle of 45° and 30° with the horizontal respectively. The ratio of their respective ranges will be

- (A) $1:\sqrt{2}$ (B) $\sqrt{2}:1$
 (C) $2:\sqrt{3}$ (D) $\sqrt{3}:2$

Official Ans. by NTA (C)

Ans. (C)

Sol. Let projection speed is u

$$R_1 = \frac{u^2 \sin(90^\circ)}{g}; R_2 = \frac{u^2 \sin(60^\circ)}{g}$$

$$\frac{R_1}{R_2} = \frac{2}{\sqrt{3}}$$

2. In a Vernier Calipers. 10 divisions of Vernier scale is equal to the 9 divisions of main scale. When both jaws of Vernier calipers touch each other, the zero of the Vernier scale is shifted to the left of zero of the main scale and 4th Vernier scale division exactly coincides with the main scale reading. One main scale division is equal to 1 mm. While measuring diameter of a spherical body, the body is held between two jaws. It is now observed that zero of the Vernier scale lies between 30 and 31 divisions of main scale reading and 6th Vernier scale division exactly coincides with the main scale reading. The diameter of the spherical body will be :

- (A) 3.02 cm (B) 3.06 cm
 (C) 3.10 cm (D) 3.20 cm

Official Ans. by NTA (C)

Ans. (C)

Sol. 1 M.S.D = 1mm

9 M.S.D = 10 V.S.D

1 V.S.D = 0.9 M.S.D = 0.9 mm

L.C of vernier caliper = $1 - 0.9 = 0.1 \text{ mm} = 0.01 \text{ cm}$

zero error = $-(10 - 4) \times 0.1 \text{ mm} = -0.6 \text{ mm}$

Reading = M.S.R + V.S.R - Zero error

$$= 3 \text{ cm} + 6 \times 0.01 - [-0.06]$$

$$= 3 + 0.06 + 0.06$$

$$= 3.12 \text{ cm}$$

Nearest given answer in the options is 3.10

3. A ball of mass 0.15 kg hits the wall with its initial speed of 12 ms^{-1} and bounces back without changing its initial speed. If the force applied by the wall on the ball during the contact is 100 N. calculate the time duration of the contact of ball with the wall.

- (A) 0.018 s (B) 0.036 s
 (C) 0.009 s (D) 0.072 s

Official Ans. by NTA (B)

Ans. (B)

Sol. $\vec{P}_i = 0.15 \times 12 (\hat{i})$

$$\vec{P}_f = 0.15 \times 12 (-\hat{i})$$

$$|\Delta \vec{P}| = 3.6 \text{ kg-m/s}$$

$$3.6 = F \Delta t$$

$$3.6 = 100 \Delta t$$

$$\Delta t = 0.036 \text{ sec}$$

4. A body of mass 8 kg and another of mass 2 kg are moving with equal kinetic energy. The ratio of their respective momenta will be :

- (A) 1:1 (B) 2:1 (C) 1:4 (D) 4:1

Official Ans. by NTA (B)

Ans. (B)

Sol. $K.E = \frac{P^2}{2m}$

$$K_1 = \frac{P_1^2}{2(8)}; K_2 = \frac{P_2^2}{2(2)}$$

$$K_1 = K_2$$

So,

$$4P_2^2 = P_1^2$$

$$\frac{P_1}{P_2} = 2$$

5. Two uniformly charged spherical conductors A and B of radii 5 mm and 10 mm are separated by a distance of 2 cm. If the spheres are connected by a conducting wire, then in equilibrium condition, the ratio of the magnitudes of the electric fields at the surface of the sphere A and B will be :

- (A) 1 : 2 (B) 2 : 1 (C) 1 : 1 (D) 1 : 4

Official Ans. by NTA (B)

Ans. (B)

Sol. $V_A = V_B$

$$\frac{KQ_A}{R_A} = \frac{KQ_B}{R_B}$$

$$\frac{Q_A}{Q_B} = \frac{R_A}{R_B} = \frac{1}{2}$$

$$E_A = \frac{KQ_A}{R_A^2}; E_B = \frac{KQ_B}{R_B^2}$$

$$\frac{E_A}{E_B} = \frac{Q_A}{Q_B} \times \frac{R_B^2}{R_A^2} = \frac{R_B}{R_A} = \frac{2}{1}$$

6. The oscillating magnetic field in a plane electromagnetic wave is given by $B_y = 5 \times 10^{-6} \sin 1000\pi (5x - 4 \times 10^8 t)$ T. The amplitude of electric field will be :

- (A) $15 \times 10^2 \text{ Vm}^{-1}$ (B) $5 \times 10^{-6} \text{ Vm}^{-1}$
 (C) $16 \times 10^{12} \text{ Vm}^{-1}$ (D) $4 \times 10^2 \text{ Vm}^{-1}$

Official Ans. by NTA (D)

Ans. (D)

Sol. $B_0 = 5 \times 10^{-6}$

$$v = \text{Speed of wave} = \frac{4 \times 10^8}{5} = 8 \times 10^7 \left[\because v = \frac{\omega}{k} \right]$$

$$E_0 = vB_0 = 40 \times 10^1 = 4 \times 10^2 \text{ V/m}$$

7. Light travels in two media M_1 and M_2 with speeds $1.5 \times 10^8 \text{ ms}^{-1}$ and $2.0 \times 10^8 \text{ ms}^{-1}$ respectively. The critical angle between them is:

- (A) $\tan^{-1}\left(\frac{3}{\sqrt{7}}\right)$ (B) $\tan^{-1}\left(\frac{2}{3}\right)$
 (C) $\cos^{-1}\left(\frac{3}{4}\right)$ (D) $\sin^{-1}\left(\frac{2}{3}\right)$

Official Ans. by NTA (A)

Ans. (A)

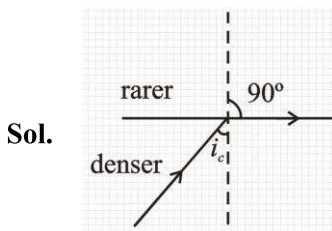

Sol.

$$v = \frac{c}{n}$$

$$n_d \sin i_c = n_r \sin 90^\circ$$

$$\sin i_c = \frac{n_r}{n_d} = \frac{v_d}{v_r}$$

$$\sin i_c = \frac{1.5 \times 10^8}{2 \times 10^8} = \frac{1.5}{2}$$

$$\sin i_c = \frac{3}{4}$$

$$\tan i_c = \frac{3}{\sqrt{4^2 - 3^2}} \Rightarrow \frac{3}{\sqrt{7}}$$

$$i_c = \tan^{-1}\left(\frac{3}{\sqrt{7}}\right)$$

8. A body is projected vertically upwards from the surface of earth with a velocity equal to one third of escape velocity. The maximum height attained by the body will be:

- (Take radius of earth = 6400 km and $g = 10 \text{ ms}^{-2}$)
 (A) 800 km (B) 1600 km
 (C) 2133 km (D) 4800 km

Official Ans. by NTA (A)

Ans. (A)

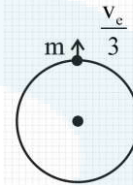

Sol.

$$v_e = \sqrt{\frac{2Gm}{R}}$$

$$\frac{-GMm}{R} + \frac{1}{2}m \frac{V_e^2}{9} = -\frac{GMm}{R+h}$$

$$\frac{GM}{R+h} = \frac{GM}{R} - \frac{V_e^2}{18}$$

$$\frac{GM}{R+h} = \frac{GM}{R} - \frac{GM}{9R}$$

$$\frac{GM}{R+h} = \frac{8GM}{9R}$$

$$\frac{1}{R+h} = \frac{8}{9R}$$

$$9R = 8R + 8h$$

$$h = \frac{R}{8} \Rightarrow \frac{6400}{8} \Rightarrow 800 \text{ km}$$

9. The maximum and minimum voltage of an amplitude modulated signal are 60 V and 20 V respectively. The percentage modulation index will be :

- (A) 0.5% (B) 50% (C) 2% (D) 30%

Official Ans. by NTA (B)

Ans. (B)

Sol. $V_{\max} = 60$
 $V_{\min} = 20$
 % modulation =

$$\left(\frac{V_{\max} - V_{\min}}{V_{\max} + V_{\min}} \right) 100 \Rightarrow \left(\frac{60 - 20}{60 + 20} \right) 100 \Rightarrow \left(\frac{40}{80} \right) 100$$

$$\Rightarrow 50\%$$

10. A nucleus of mass M at rest splits into two parts having masses $\frac{M'}{3}$ and $\frac{2M'}{3}$ ($M' < M$). The ratio of de Broglie wavelength of two parts will be :
 (A) 1 : 2 (B) 2 : 1
 (C) 1 : 1 (D) 2 : 3

Official Ans. by NTA (C)

Ans. (C)

Sol.

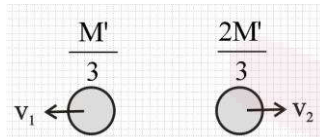

$$|\vec{P}_1| = |\vec{P}_2|$$

Here \vec{P} is momentum

$$\text{So } \lambda = \frac{h}{P}$$

Hence both will have same de broglie wavelength.

11. An ice cube of dimensions $60 \text{ cm} \times 50 \text{ cm} \times 20 \text{ cm}$ is placed in an insulation box of wall thickness 1 cm . The box keeping the ice cube at 0°C of temperature is brought to a room of temperature 40°C . The rate of melting of ice is approximately: (Latent heat of fusion of ice is $3.4 \times 10^5 \text{ J kg}^{-1}$ and thermal conducting of insulation wall is $0.05 \text{ Wm}^{-1}\text{C}^{-1}$)
 (A) $61 \times 10^{-1} \text{ kg s}^{-1}$ (B) $61 \times 10^{-5} \text{ kg s}^{-1}$
 (C) 208 kg s^{-1} (D) $30 \times 10^{-5} \text{ kg s}^{-1}$

Official Ans. by NTA (B)

Ans. (B)

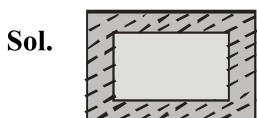

$$\frac{dQ}{dt} = \frac{KA\Delta T}{\ell}$$

$$A = 2 (0.6 \times 0.5 + 0.5 \times 0.2 + 0.2 \times 0.6)$$

$$= 2(0.3 + 0.1 + 0.12)$$

$$= 2(0.4 + 0.12)$$

$$= 2(0.52)$$

$$= 1.04 \text{ m}^2$$

$$R_{\text{th}} = \frac{\ell}{KA} \Rightarrow \frac{1 \times 10^{-2}}{0.05 \times 1.04} \Rightarrow \frac{10^{-2}}{0.052}$$

$$\frac{dQ}{dt} = \frac{\Delta T}{R_{\text{th}}} \Rightarrow \frac{40 \times 0.052}{10^{-2}} \Rightarrow 2.08 \times 10^2 \text{ J/s}$$

$$2.08 \times 10^2 = m \times 3.4 \times 10^5$$

$$m = \frac{2.08}{3.4 \times 10^3} \Rightarrow 0.61 \times 10^{-3} \text{ kg/s}$$

$$= 61 \times 10^{-5} \text{ Kg/s}$$

12. A gas has n degrees of freedom. The ratio of specific heat of gas at constant volume to the specific heat of gas at constant pressure will be :

- (A) $\frac{n}{n+2}$ (B) $\frac{n+2}{n}$
 (C) $\frac{n}{2n+2}$ (D) $\frac{n}{n-2}$

Official Ans. by NTA (A)

Ans. (A)

Sol. $C_v = \frac{nR}{2}$ $C_p = \frac{(n+2)R}{2}$

$$\frac{C_v}{C_p} = \frac{n}{n+2}$$

13. A transverse wave is represented by $y = 2 \sin(\omega t - kx)$ cm. The value of wavelength (in cm) for which the wave velocity becomes equal to the maximum particle velocity, will be ;

- (A) 4π (B) 2π
 (C) π (D) 2

Official Ans. by NTA (A)

Ans. (A)

Sol. $y = 2 \sin(\omega t - kx)$

Maximum particle velocity = $A \omega$

$$\text{Wave velocity} = \frac{\omega}{k}$$

$$\frac{\omega}{k} = A \omega$$

$$k = \frac{1}{A} = \frac{2\pi}{\lambda}$$

$$\lambda = 2\pi A$$

$$= 4 \pi \text{ cm}$$

14. A battery of 6 V is connected to the circuit as shown below. The current I drawn from the battery is :

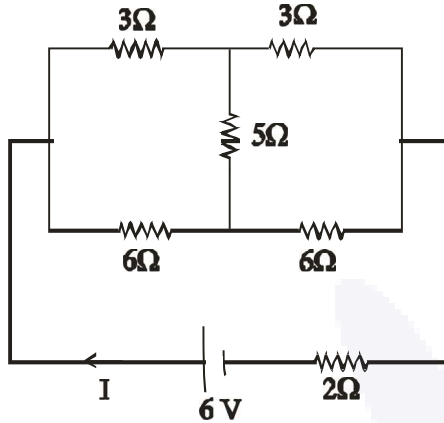

- (A) 1A (B) 2A
(C) $\frac{6}{11}$ A (D) $\frac{4}{3}$ A

Official Ans. by NTA (A)

Ans. (A)

- Sol.** Balanced wheat stone bridge in circuit so there is no current in 5 Ω resistor so it can be removed from the circuit.

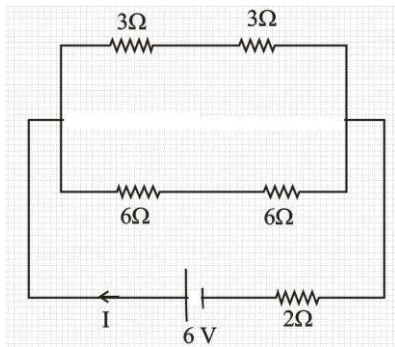

$$R_{eq} = \frac{6 \times 12}{6 + 12} + 2$$

$$= \frac{6 \times 12}{18} + 2$$

$$R_{eq} = 6\Omega$$

$$I = \frac{V}{R_{eq}} = \frac{6}{6} = 1 \text{ Amp.}$$

15. A source of potential difference V is connected to the combination of two identical capacitors as shown in the figure. When key 'K' is closed, the total energy stored across the combination is E_1 . Now key 'K' is opened and dielectric of dielectric constant 5 is introduced between the plates of the capacitors. The total energy stored across the combination is now E_2 . The ratio E_1/E_2 will be :

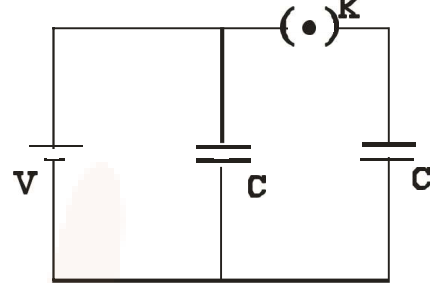

- (A) $\frac{1}{10}$ (B) $\frac{2}{5}$
(C) $\frac{5}{13}$ (D) $\frac{5}{26}$

Official Ans. by NTA (C)

Ans. (C)

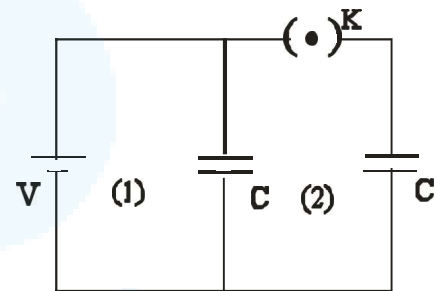

Sol.

- (1) Switch is closed

$$C_{eq} = 2C$$

$$\text{Energy } E_1 = \frac{1}{2} C_{eq} V^2$$

$$= \frac{1}{2} 2C \times V^2$$

$$E_1 = CV^2$$

- (ii) When switch is opened charge on right capacitor remain CV while potential on left capacitor remain same

$$\text{Dielectric } K = 5$$

$$C' = KC$$

$$C' = 5C$$

$$E_2 = \frac{1}{2} (5C) V^2 + \frac{(CV)^2}{2(5C)}$$

$$E_2 = \frac{5CV^2}{2} + \frac{CV^2}{10}$$

$$E_2 = \frac{13CV^2}{5}$$

$$\frac{E_1}{E_2} = \frac{CV^2}{\frac{13CV^2}{5}} = \frac{5}{13}$$

$$\frac{E_1}{E_2} = \frac{5}{13}$$

16. Two concentric circular loops of radii $r_1=30$ cm and $r_2=50$ cm are placed in X-Y plane as shown in the figure. A current $I = 7A$ is flowing through them in the direction as shown in figure. The net magnetic moment of this system of two circular loops is approximately :

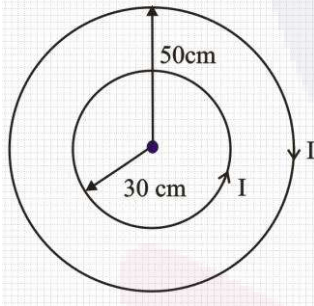

- (A) $\frac{7}{2}\hat{k}$ Am² (B) $-\frac{7}{2}\hat{k}$ Am²
 (C) $7\hat{k}$ Am² (D) $-7\hat{k}$ Am²

Official Ans. by NTA (B)

Ans. (B)

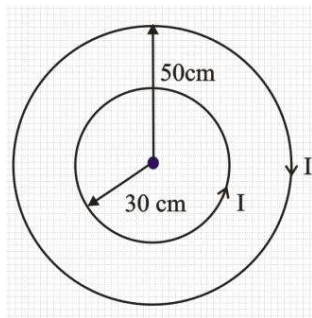

Sol.

Magnetic moment

$$\vec{M} = -i\pi(0.5)^2 \hat{k} + i\pi(0.3)^2 \hat{k}$$

$$\vec{M} = -7 \times \frac{22}{7} \left(\frac{25}{100} - \frac{9}{100} \right) \hat{k}$$

$$= -22 \left(\frac{16}{100} \right) \hat{k}$$

$$\vec{M} = -3.52\hat{k} \text{ Am}^2$$

$$= -\frac{7}{2}\hat{k} \text{ Am}^2$$

17. A velocity selector consists of electric field $\vec{E} = E\hat{k}$ and magnetic field $\vec{B} = B\hat{j}$ with $B=12$ mT. The value E required for an electron of energy 728 eV moving along the positive x-axis to pass undeflected is :

(Given, mass of electron = 9.1×10^{-31} kg)

- (A) 192 kVm⁻¹ (B) 192 m Vm⁻¹
 (C) 9600 kVm⁻¹ (D) 16 kVm⁻¹

Official Ans. by NTA (A)

Ans. (A)

Sol. $\vec{E} = E\hat{k}$ $B = 12$ mT

$\vec{B} = B\hat{j}$ Energy = 728 eV

$$\text{Energy} = \frac{1}{2}mv^2$$

$$728\text{eV} = \frac{1}{2} \times 9.1 \times 10^{-31} \times v^2$$

$$728 \times 1.6 \times 10^{-19} = \frac{1}{2} \times 9.1 \times 10^{-31} \times v^2$$

$$v = 16 \times 10^6 \text{ m/s}$$

$$E = vB$$

$$E = 16 \times 10^6 \times 12 \times 10^{-3}$$

$$E = 192 \times 10^3 \text{ V/m}$$

18. Two masses M_1 and M_2 are tied together at the two ends of a light inextensible string that passes over a frictionless pulley. When the mass M_2 is twice that of M_1 , the acceleration of the system is a_1 . When the mass M_2 is thrice that of M_1 . The acceleration of The system is a_2 . The ratio $\frac{a_1}{a_2}$ will be:

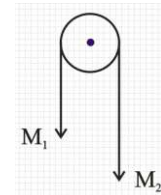

- (A) $\frac{1}{3}$ (B) $\frac{2}{3}$

- (C) $\frac{3}{2}$ (D) $\frac{1}{2}$

Official Ans. by NTA (B)

Ans. (B)

Sol. $a = \frac{m_2g - m_1g}{m_1 + m_2}$

Case 1 $M_2 = 2m_1$

$$a_1 = \frac{2m_1g - m_1g}{3m_1}$$

$$a_1 = g/3$$

3. In the given figure, the face AC of the equilateral prism is immersed in a liquid of refractive index 'n'. For incident angle 60° at the side AC, the refracted light beam just grazes along face AB.

The refractive index of the liquid $n = \frac{\sqrt{x}}{4}$. The value of x is _____.

(Given refractive index of glass = 1.5)

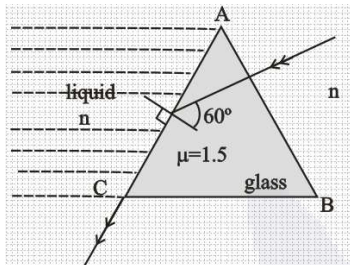

Official Ans. by NTA (27)

Ans. (27)

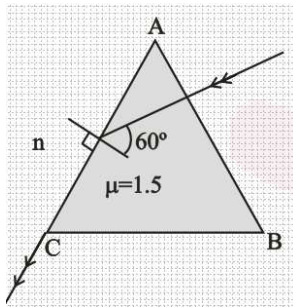

Sol.

Using snell's law at face AC

$$1.5 \sin 60^\circ = n \times \sin 90^\circ$$

$$1.5 \times \frac{\sqrt{3}}{2} = n = \frac{\sqrt{x}}{4}$$

$$3\sqrt{3} = \sqrt{x}$$

$$x = 27$$

4. Two lighter nuclei combine to form a comparatively heavier nucleus by the relation given below:

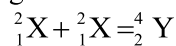

The binding energies per nucleon ${}^2_1\text{X}$ and ${}^4_2\text{Y}$ are 1.1 MeV and 7.6 MeV respectively. The energy released in this process is _____ MeV.

Official Ans. by NTA (26)

Ans. (26)

Sol. Energy released in the given process = Binding energy of product – Binding energy of reactants

$$= 7.6 \times 4 - (1.1 \times 2) \times 2$$

$$= 30.4 - 4.4$$

$$= 26 \text{ MeV}$$

5. A uniform heavy rod of mass 20 kg. Cross sectional area 0.4 m^2 and length 20 m is hanging from a fixed support. Neglecting the lateral contraction, the elongation in the rod due to its own weight is $x \times 10^{-9} \text{ m}$. The value of x is _____.

:(Given. Young's modulus $Y = 2 \times 10^{11} \text{ Nm}^{-2}$ and $g = 10 \text{ ms}^{-2}$)

Official Ans. by NTA (25)

Ans. (25)

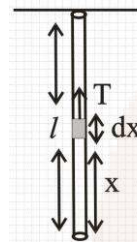

Sol.

$$Y = \frac{T}{A} \frac{dx}{dy}$$

$$m = 20 \text{ kg}$$

$$A = 0.4 \text{ m}^2$$

$$l = 20 \text{ m}$$

let extension is dy in length dx

$$Y = \frac{\text{stress}}{\text{strain}}$$

$$Y = \frac{T}{A} = \frac{T}{A} \frac{dx}{dy}$$

$$dy = \frac{T dx}{AY}$$

$$\text{Tension at a distance } x \text{ from lower end} = \frac{mg}{l} x$$

$$\text{So, } \int_0^l dy = \int_0^l \frac{mg}{lAY} x \frac{dx}{AY}$$

$$\Delta l = \frac{mg}{lAY} \left[\frac{x^2}{2} \right]_0^l$$

$$\Delta l = \frac{mg l}{2AY}$$

$$\Delta l = \frac{20 \times 10 \times 20}{2 \times 0.4 \times 2 \times 10^{11}}$$

$$2500 \times 10^{-11}$$

$$\Delta l = 25 \times 10^{-9}$$

$$= x \times 10^{-9}$$

$$x = 25$$

The typical transfer characteristic of a transistor in CE configuration is shown in figure. A load resistor of $2\text{ k}\Omega$ is connected in the collector branch of the circuit used. The input resistance of the transistor is $0.50\text{ k}\Omega$. The voltage gain of the transistor is

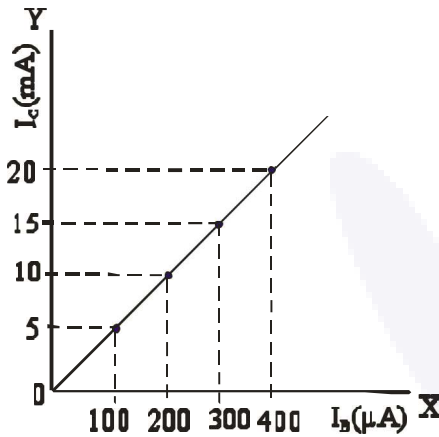

Official Ans. by NTA (200)

Ans. (200)

Sol. Current gain in C-E configuration

$$\Rightarrow \beta = \frac{\Delta I_C}{\Delta I_B}$$

$$R_C = 2\text{ k}\Omega, R_B = 0.50\text{ k}\Omega$$

$$\text{Voltage gain} = \frac{\Delta I_C R_C}{\Delta I_B R_B} = \frac{5 \times 10^{-3}}{100 \times 10^{-6}} \times \frac{2}{0.5}$$

$$= \frac{10^{-2}}{5 \times 10^{-5}} = \frac{1000}{5} = 200$$

7. Three point charges of magnitude $5\mu\text{C}$, $0.16\mu\text{C}$ and $0.3\mu\text{C}$ are located at the vertices A, B, C of a right angled triangle whose sides are $AB = 3\text{cm}$, $BC = 3\sqrt{2}\text{ cm}$ and $CA = 3\text{ cm}$ and point A is the right angle corner. Charge at point A experiences _____ N of electrostatic force due to the other two charges.

Official Ans. by NTA (17)

Ans. (17)

Sol.

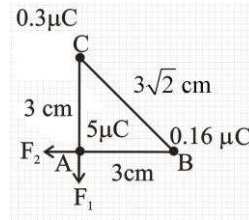

$$F_1 = \frac{k \times 5 \times 0.3 \times 10^{-12}}{9 \times 10^{-4}}$$

$$= \frac{9 \times 10^9 \times 5 \times 0.3 \times 10^{-12}}{9 \times 10^{-4}}$$

$$= 1.5 \times 10 = 15\text{ N}$$

$$F_2 = \frac{9 \times 10^9 \times 5 \times 0.16 \times 10^{-12}}{9 \times 10^{-4}} = 8\text{ N}$$

$$\text{force experienced by charge at A} = \sqrt{F_1^2 + F_2^2}$$

$$= \sqrt{15^2 + 8^2}$$

$$= \sqrt{289} = 17\text{ N}$$

8. In a coil of resistance 8Ω , the magnetic flux due to an external magnetic field varies with time as $\phi = \frac{2}{3}(9 - t^2)$. The value of total heat produced in the coil, till the flux becomes zero, will be _____ J.

Official Ans. by NTA (2)

Ans. (2)

Sol. $\phi = \frac{2}{3}(9 - t^2) = 0$

$$t = 3\text{ sec}$$

$$e = \frac{-d\phi}{dt} = -\frac{2}{3}(0 - 2t) = \frac{4t}{3}$$

$$\text{Heat produced in 3 sec} = \int \frac{e^2}{r} dt = \int_0^3 \frac{16t^2}{9 \times 8} dt = 2\text{ J}$$

9. A potentiometer wire of length 300 cm is connected in series with a resistance 780Ω and a standard cell of emf 4V. A constant current flows through potentiometer wire. The length of the null point for cell of emf 20 mV is found to be 60 cm. The resistance of the potentiometer wire is $\underline{\hspace{2cm}} \Omega$.

Official Ans. by NTA (20)

Ans. (20)

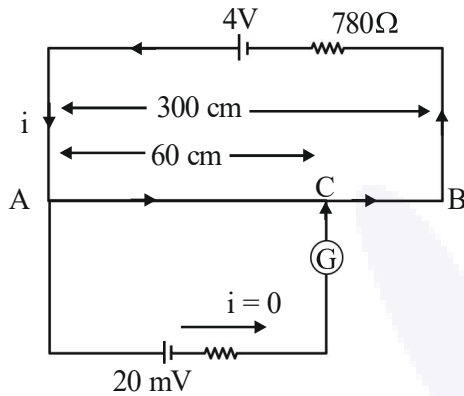

Sol.

Let resistance of potentiometers wire is R

$$i = \frac{4}{R + 780}$$

Potential difference across AB

$$= \frac{4R}{R + 780}$$

Potential difference across AC

$$= \frac{4R \times 60}{(R + 780) \times 300} = \frac{4R}{5(R + 780)}$$

This should be equal to 20 mV

$$\frac{4R}{5(R + 780)} = 20 \times 10^{-3} = 2 \times 10^{-2}$$

$$4R = 10^{-1}(R + 780)$$

$$4R = \frac{R}{10} + 78$$

$$4R - \frac{R}{10} = 78$$

$$\frac{39R}{10} = 78$$

$$\boxed{R = 20\Omega}$$

10. As per given figures, two springs of spring constants K and 2K are connected to mass m. If the period of oscillation in figure (a) is 3s, then the period of oscillation in figure (b) will be \sqrt{x} s. The value of x is $\underline{\hspace{2cm}}$.

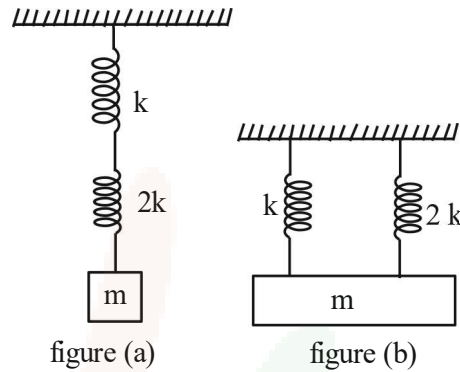

Official Ans. by NTA (2)

Ans. (2)

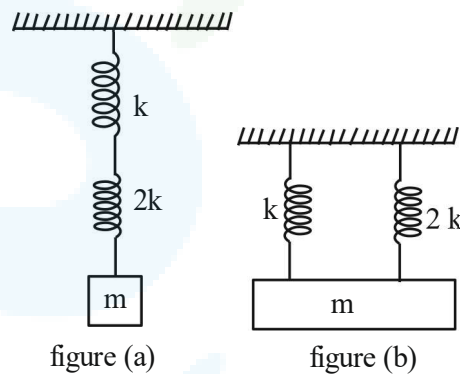

Sol.

For figure (a) :

$$K_{eq} = \frac{K \times 2K}{K + 2K} = \frac{2K}{3}$$

$$T = 2\pi \sqrt{\frac{m}{K_{eq}}} = 2\pi \sqrt{\frac{m}{2K/3}} = 2\pi \sqrt{\frac{3m}{2K}}$$

For figure (b):

$$K_{eq} = 3K, T' = 2\pi \sqrt{\frac{m}{3K}}$$

$$\frac{T'}{T} = \sqrt{\frac{m \times 2K}{3K \times 3m}} = \frac{\sqrt{2}}{3}$$

$$T' = \sqrt{2}$$

$$x = 2$$