



FINAL JEE–MAIN EXAMINATION – AUGUST, 2021

Held On Thursday 26th August, 2021

TIME: 3:00 PM to 06:00 PM

SECTION-A

1. The temperature of equal masses of three different liquids x,y and z are 10°C, 20°C and 30°C respectively. The temperature of mixture when x is mixed with y is 16°C and that when y is mixed with z is 26°C. The temperature of mixture when x and z are mixed will be :

- (1) 28.32° C (2) 25.62° C
- (3) 23.84° C (4) 20.28° C

Official Ans. by NTA (3)

Sol.	X	Y	Z
	$m_1 = m$	$m_2 = m$	$m_3 = m$
	$T_1 = 10^\circ\text{C}$	$T_2 = 20^\circ\text{C}$	$T_3 = 30^\circ\text{C}$
	s_1	s_2	s_3

when x & y are mixed, $T_f = 16^\circ\text{C}$

$$m_1s_1T + m_2s_2T_2 = (m_1s_1 + m_2s_2)T_f$$

$$s_1 \times 10 + s_2 \times 20 = (s_1 + s_2) \times 16$$

$$s_1 = \frac{2}{3}s_2 \quad \dots(i)$$

when y & z are mixex, $T_{f_2} = 26^\circ\text{C}$

$$m_2s_2T + m_3s_3T_3 = (m_3s_3 + m_3s_3)T_{f_2}$$

$$s_2 \times 20 + s_3 \times 30 = (s_2 + s_3) \times 26$$

$$s_3 = \frac{3}{2}s_2 \quad \dots(ii)$$

when x & z are mixex

$$m_1s_1T_1 + m_3s_3T_3 = (m_1s_1 + m_3s_3)T_f$$

$$\frac{2}{3}s_2 \times 10 + \frac{2}{3}s_2 \times 20 = \left(\frac{2}{3}s_2 + \frac{3}{2}s_2\right)T_f$$

$$T_f = 23.84^\circ\text{C}$$

Ans (3)

2. The de-Broglie wavelength of a particle having kinetic energy E is λ . How much extra energy must be given to this particle so that the de-Broglie wavelength reduces to 75% of the initial value ?

- (1) $\frac{1}{9}E$ (2) $\frac{7}{9}E$
- (3) E (4) $\frac{16}{9}E$

Official Ans. by NTA (2)

Sol. $\lambda = \frac{h}{mv} = \frac{h}{\sqrt{2mE}}$

$$\lambda \propto \frac{1}{\sqrt{E}}$$

$$\frac{\lambda_2}{\lambda_1} = \sqrt{\frac{E_1}{E_2}} = \frac{3}{4}, \lambda_2 = 0.75 \lambda_1$$

$$\frac{E_1}{E_2} = \left(\frac{3}{4}\right)^2$$

$$E_2 = \frac{16}{9}E_1 = \frac{16}{9}E \quad (E_1 = E)$$

$$\text{Extra energy given} = \frac{16}{9}E - E = \frac{7}{9}E$$

Ans. 2

3. A particle of mass m is suspended from a ceiling through a string of length L. The particle moves in a horizontal circle of radius r such that $r = \frac{L}{\sqrt{2}}$. The speed of particle will be :

- (1) \sqrt{rg} (2) $\sqrt{2rg}$ (3) $2\sqrt{rg}$ (4) $\sqrt{\frac{rg}{2}}$

Official Ans. by NTA (1)

Sol. Conical pendulum

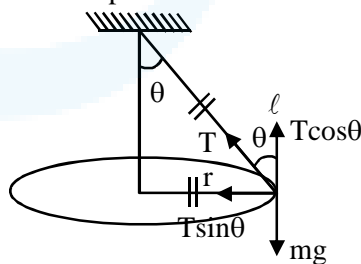

$$r = \frac{l}{\sqrt{2}}$$

$$\sin \theta = \frac{r}{l} = \frac{1}{\sqrt{2}}$$

$$\theta = 45^\circ$$

$$T \sin \theta = \frac{mv^2}{r}$$

$$T \cos \theta = mg$$

$$\tan \theta = \frac{v^2}{rg} \Rightarrow v = \sqrt{rg}$$

Ans. 1



4. A cylindrical container of volume $4.0 \times 10^{-3} \text{ m}^3$ contains one mole of hydrogen and two moles of carbon dioxide. Assume the temperature of the mixture is 400 K. The pressure of the mixture of gases is :

[Take gas constant as $8.3 \text{ J mol}^{-1} \text{ K}^{-1}$]

- (1) $249 \times 10^1 \text{ Pa}$ (2) $24.9 \times 10^3 \text{ Pa}$
 (3) $24.9 \times 10^5 \text{ Pa}$ (4) 24.9 Pa

Official Ans. by NTA (3)

Sol. $V = 4 \times 10^{-3} \text{ m}^3$

$n = 3 \text{ moles}$

$T = 400\text{K}$

$$PV = nRT \Rightarrow P = \frac{nRT}{V}$$

$$P = \frac{3 \times 8.3 \times 400}{4 \times 10^{-3}}$$

$$= 24.9 \times 10^5 \text{ Pa}$$

Ans 3

5. The angle between vector (\vec{A}) and $(\vec{A} - \vec{B})$ is :

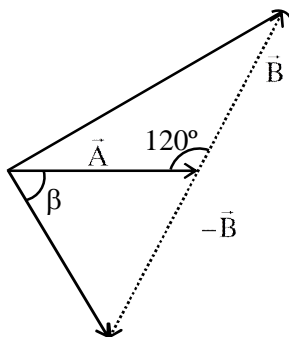

(1) $\tan^{-1} \left(\frac{\frac{B}{2}}{A - B \frac{\sqrt{3}}{2}} \right)$

(2) $\tan^{-1} \left(\frac{A}{0.7B} \right)$

(3) $\tan^{-1} \left(\frac{\sqrt{3}B}{2A - B} \right)$

(4) $\tan^{-1} \left(\frac{B \cos \theta}{A - B \sin \theta} \right)$

Official Ans. by NTA (3)

Sol.

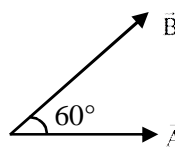
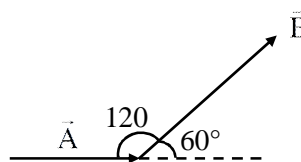

Angle between \vec{A} and \vec{B} , $\theta = 60^\circ$

Angle between \vec{A} and $\vec{A} - \vec{B}$

$$\tan \alpha = \frac{B \sin \theta}{A - B \cos \theta}$$

$$= \frac{B \frac{\sqrt{3}}{2}}{A - B \times \frac{1}{2}}$$

$$\tan \alpha = \frac{\sqrt{3}B}{2A - B}$$

Ans 3

6. A light beam is described by $E = 800 \sin \omega \left(t - \frac{x}{c} \right)$

.An electron is allowed to move normal to the propagation of light beam with a speed of $3 \times 10^7 \text{ ms}^{-1}$. What is the maximum magnetic force exerted on the electron ?

- (1) $1.28 \times 10^{-18} \text{ N}$
 (2) $1.28 \times 10^{-21} \text{ N}$
 (3) $12.8 \times 10^{-17} \text{ N}$
 (4) $12.8 \times 10^{-18} \text{ N}$

Official Ans. by NTA (4)

Sol. $\frac{E_0}{C} = B_0$

$$F_{\max} = eB_0 v$$

$$= 1.6 \times 10^{-19} \times \frac{800}{3 \times 10^8} \times 3 \times 10^7$$

$$= 12.8 \times 10^{-18} \text{ N}$$

Ans. 4



7. The two thin coaxial rings, each of radius 'a' and having charges +Q and -Q respectively are separated by a distance of 's'. The potential difference between the centres of the two rings is :

(1) $\frac{Q}{2\pi\epsilon_0} \left[\frac{1}{a} + \frac{1}{\sqrt{s^2 + a^2}} \right]$

(2) $\frac{Q}{4\pi\epsilon_0} \left[\frac{1}{a} + \frac{1}{\sqrt{s^2 + a^2}} \right]$

(3) $\frac{Q}{4\pi\epsilon_0} \left[\frac{1}{a} - \frac{1}{\sqrt{s^2 + a^2}} \right]$

(4) $\frac{Q}{2\pi\epsilon_0} \left[\frac{1}{a} - \frac{1}{\sqrt{s^2 + a^2}} \right]$

Official Ans. by NTA (4)

Sol.

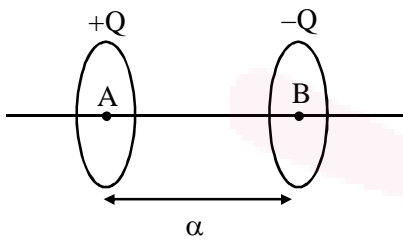

$$V_A = \frac{KQ}{a} - \frac{KQ}{\sqrt{a^2 + s^2}}$$

$$V_B = \frac{-KQ}{a} + \frac{KQ}{\sqrt{a^2 + s^2}}$$

$$V_A - V_B = \frac{2KQ}{a} - \frac{2KQ}{\sqrt{a^2 + s^2}}$$

$$= \frac{Q}{2\pi\epsilon_0} \left(\frac{1}{a} - \frac{1}{\sqrt{s^2 + a^2}} \right)$$

Ans 4

8. If you are provided a set of resistances 2Ω, 4Ω, 6Ω and 8Ω. Connect these resistances so as to obtain an equivalent resistance of $\frac{46}{3}\Omega$.

- (1) 4Ω and 6Ω are in parallel with 2Ω and 8 Ω in series
- (2) 6Ω and 8Ω are in parallel with 2Ω and 4Ω in series
- (3) 2Ω and 6Ω are in parallel with 4Ω and 8 Ω in series
- (4) 2Ω and 4Ω are in parallel with 6Ω and 8Ω in series

Official Ans. by NTA (4)

Sol.

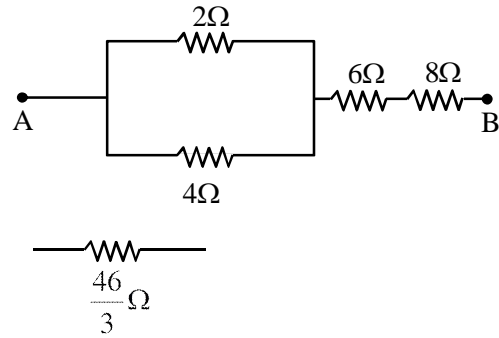

Ans 4

9. The solid cylinder of length 80 cm and mass M has a radius of 20 cm. Calculate the density of the material used if the moment of inertia of the cylinder about an axis CD parallel to AB as shown in figure is 2.7 kg m².

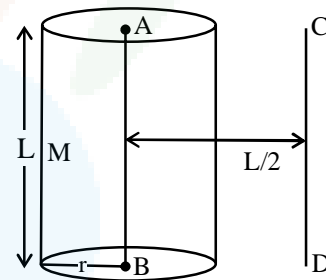

- (1) 14.9 kg / m³
- (2) 7.5 × 10¹ kg / m³
- (3) 7.5 × 10² kg/m³
- (4) 1.49 × 10² kg / m³

Official Ans. by NTA (4)

Sol. Parallel axis theorem

$$I = I_{CM} + Md^2$$

$$I = \frac{Mr^2}{2} + M\left(\frac{L}{2}\right)^2$$

$$2.7 = M\frac{(0.2)^2}{2} + M\left(\frac{0.8}{2}\right)^2$$

$$2.7 = M\left[\frac{2}{100} + \frac{16}{100}\right]$$

$$M = 15\text{kg}$$

$$\Rightarrow \rho = \frac{M}{\pi r^2 L} = \frac{15}{\pi(0.2)^2 \times 0.8}$$

$$= 0.1492 \times 10^3$$

Ans. 4



10. A parallel - plate capacitor with plate area A has separation d between the plates. Two dielectric slabs of dielectric constant K_1 and K_2 of same area $A/2$ and thickness $d/2$ are inserted in the space between the plates. The capacitance of the capacitor will be given by :

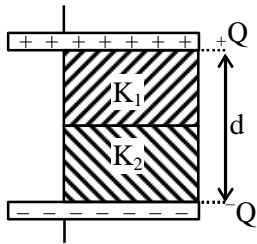

- (1) $\frac{\epsilon_0 A}{d} \left(\frac{1}{2} + \frac{K_1 K_2}{K_1 + K_2} \right)$
- (2) $\frac{\epsilon_0 A}{d} \left(\frac{1}{2} + \frac{K_1 K_2}{2(K_1 + K_2)} \right)$
- (3) $\frac{\epsilon_0 A}{d} \left(\frac{1}{2} + \frac{K_1 + K_2}{K_1 K_2} \right)$
- (4) $\frac{\epsilon_0 A}{d} \left(\frac{1}{2} + \frac{2(K_1 + K_2)}{K_1 K_2} \right)$

Official Ans. by NTA (1)

Sol.
$$C_{eq} = \frac{\frac{A}{2} \epsilon_0}{d} + \frac{A \epsilon_0}{d} \frac{K_1 K_2}{K_1 + K_2}$$

$$= \frac{A \epsilon_0}{d} \left(\frac{1}{2} + \frac{K_1 K_2}{K_1 + K_2} \right)$$

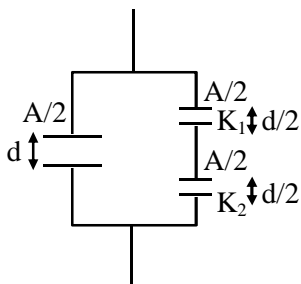

Ans.1

11. A bomb is dropped by fighter plane flying horizontally. To an observer sitting in the plane, the trajectory of the bomb is a :

- (1) hyperbola
- (2) parabola in the direction of motion of plane
- (3) straight line vertically down the plane
- (4) parabola in a direction opposite to the motion of plane

Official Ans. by NTA (3)

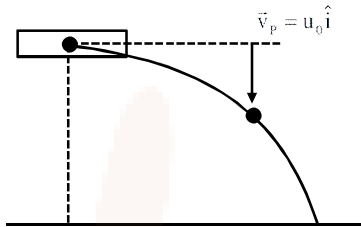

Sol.

$$v_B = u_0 \hat{i} - gt \hat{j}$$

$$\vec{v}_{B/P} = \vec{v}_B - \vec{v}_P$$

$$\vec{v}_{B/P} = -8t \hat{j}$$

straight line vertically down

Ans.3

12. At time $t = 0$, a material is composed of two radioactive atoms A and B, where $N_A(0) = 2N_B(0)$. The decay constant of both kind of radioactive atoms is λ . However, A disintegrates to B and B disintegrates to C. Which of the following figures represents the evolution of $N_B(t) / N_B(0)$ with respect to time t ?

$$\left[\begin{array}{l} N_A(0) = \text{No. of A atoms at } t = 0 \\ N_B(0) = \text{No. of B atoms at } t = 0 \end{array} \right]$$

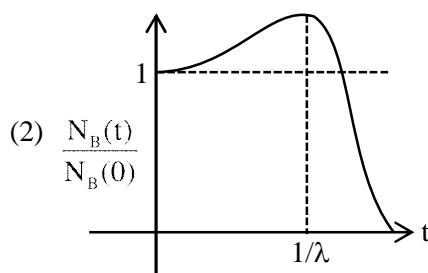
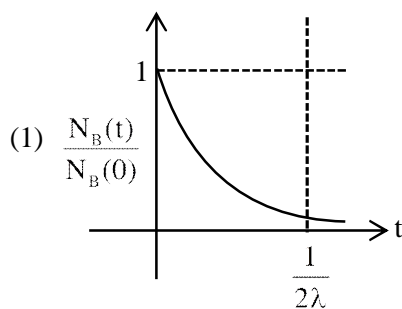

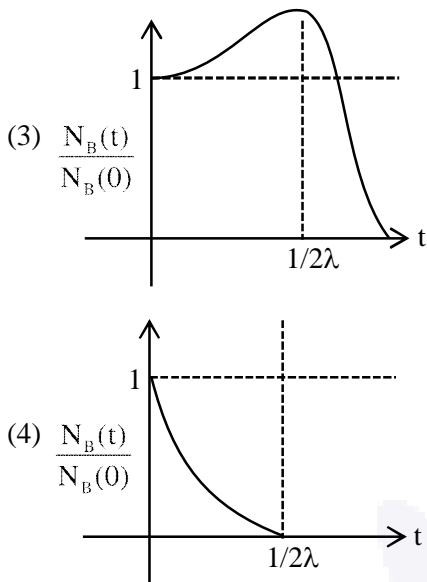

Official Ans. by NTA (3)

Sol.

A → B, B → C

$$\frac{dN_B}{dt} = \lambda N_A - \lambda N_B$$

$$\frac{dN_B}{dt} = 2\lambda N_{B_0} e^{-\lambda t} - \lambda N_B$$

$$e^{-\lambda t} \left(\frac{dN_B}{dt} + \lambda N_B \right) = 2\lambda N_{B_0} e^{-\lambda t} \times e^{\lambda t}$$

$$\frac{d}{dt} (N_B e^{\lambda t}) = 2\lambda N_{B_0}, \text{ on integrating}$$

$$N_B e^{\lambda t} = 2\lambda t N_{B_0} + N_{B_0}$$

$$N_B = N_{B_0} [1 + 2\lambda t] e^{-\lambda t}$$

$$\frac{dN_B}{dt} = 0 \text{ at } -\lambda [1 + 2\lambda t] e^{-\lambda t} + 2\lambda e^{-\lambda t} = 0$$

$$N_{B_{\max}} \text{ at } t = \frac{1}{2\lambda}$$

13. A transmitting antenna at top of a tower has a height of 50 m and the height of receiving antenna is 80 m. What is range of communication for Line of Sight (LoS) mode ?

[use radius of earth = 6400 km]

- (1) 45.5 km (2) 80.2 km
 (3) 144.1 km (4) 57.28 km

Official Ans. by NTA (4)

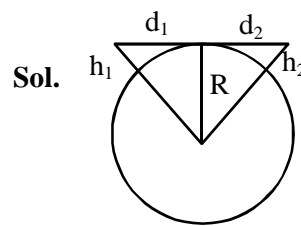

$$\begin{aligned} d &= \sqrt{2Rh_1} + \sqrt{2Rh_2} \\ &= \sqrt{2R} (\sqrt{h_1} + \sqrt{h_2}) \\ &= (2 \times 6400 \times 10^3)^{1/2} (\sqrt{50} + \sqrt{80}) \\ &= 3578 (7.07 + 8.94) \\ &= 57.28 \text{ Km} \end{aligned}$$

14. A refrigerator consumes an average 35 W power to operate between temperature -10°C to 25°C . If there is no loss of energy then how much average heat per second does it transfer ?

- (1) 263 J/s (2) 298 J/s (3) 350 J/s (4) 35 J/s

Official Ans. by NTA (1)

Sol. $\frac{T_L}{T_H - T_L} = \text{C.O.P.} = \frac{dH}{dW}$

$$\frac{263}{35} \times 35 = \frac{dH}{dt}$$

$$\frac{dH}{dt} = 263 \text{ watts}$$

Ans.1

15. An electric bulb of 500 watt at 100 volt is used in a circuit having a 200 V supply. Calculate the resistance R to be connected in series with the bulb so that the power delivered by the bulb is 500 W.

- (1) 20 Ω (2) 30 Ω (3) 5 Ω (4) 10 Ω

Official Ans. by NTA (1)

500 watt at 100 v

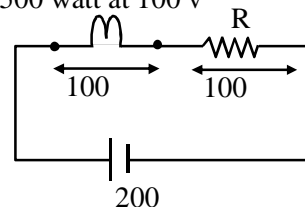

Sol.

$$P = Vi$$

$$500 = Vi$$

$$i = 5 \text{ Amp}$$

$$V = i \times R$$

$$R = 20$$

Ans. 1



16. Four NOR gates are connected as shown in figure.

The truth table for the given figure is :

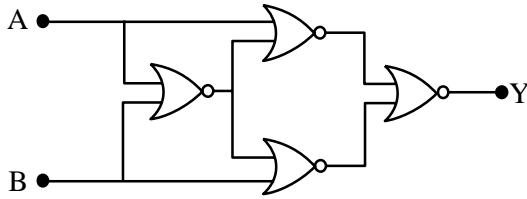

A	B	Y
0	0	1
0	1	0
1	0	1
1	1	0

A	B	Y
0	0	0
0	1	1
1	0	0
1	1	1

Official Ans. by NTA (4)

Sol.

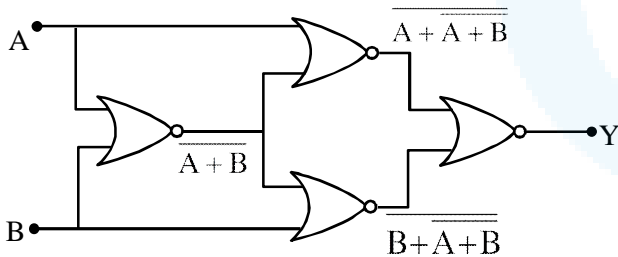

$$y = \overline{\overline{(A + A + B)} + \overline{\overline{(B + A + B)}}}$$

$$y = \overline{(A + A + B) \cdot (B + A + B)}$$

A	B	y
0	0	1
0	1	0
1	0	0
1	1	1

Ans.4

17. Match List-I with List-II.

List-I		List-II	
(a)	Magnetic Induction	(i)	$ML^2T^{-2}A^{-1}$
(b)	Magnetic Flux	(ii)	$M^0L^{-1}A$
(c)	Magnetic Permeability	(iii)	$MT^{-2}A^{-1}$
(d)	Magnetization	(iv)	$MLT^{-2}A^{-2}$

Choose the most appropriate answer from the options given below :

- (1) (a)-(ii), (b)-(iv), (c)-(i), (d)-(iii)
- (2) (a)-(ii), (b)-(i), (c)-(iv), (d)-(iii)
- (3) (a)-(iii), (b)-(ii), (c)-(iv), (d)-(i)
- (4) (a)-(iii), (b)-(i), (c)-(iv), (d)-(ii)

Official Ans. by NTA (4)

Sol. (a) Magnetic Induction = $MT^{-2}A^{-1}$

(b) Magnetic Flux = $ML^2T^{-2}A^{-1}$

(c) Magnetic Permeability = $MLT^{-2}A^{-2}$

(d) Magnetization = $M^0L^{-1}A$

Ans. 4

18. In the given circuit the AC source has $\omega = 100 \text{ rad s}^{-1}$. Considering the inductor and capacitor to be ideal, what will be the current I flowing through the circuit?

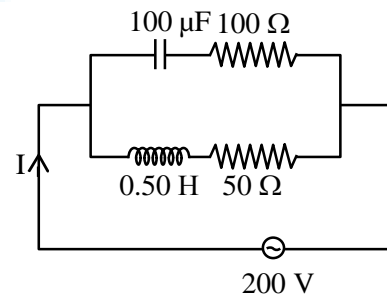

- (1) 5.9 A
- (2) 4.24 A
- (3) 0.94 A
- (4) 6 A

Official Ans. by NTA (2)

Sol. $Z_C = \sqrt{\left(\frac{1}{\omega C}\right)^2 + R^2}$

$$= \sqrt{\left(\frac{1}{100 \times 100 \times 10^{-6}}\right)^2 + 100^2}$$

$$Z_C = \sqrt{(100)^2 + (100)^2}$$

$$= 100\sqrt{2}$$

$$Z_L = \sqrt{(\omega L)^2 + R^2}$$

$$\sqrt{(100 \times 0.5)^2 + 50^2}$$

$$= 50\sqrt{2}$$

$$i_C = \frac{200}{Z_C} = \frac{200}{100\sqrt{2}} = \sqrt{2}$$

$$i_L = \frac{200}{Z_L} = \frac{200}{50\sqrt{2}} = 2\sqrt{2}$$

$$\cos \phi_1 = \frac{100}{10\sqrt{2}} = \frac{1}{\sqrt{2}} \Rightarrow \phi_1 = 45^\circ$$

$$\cos \phi_2 = \frac{50}{50\sqrt{2}} = \frac{1}{\sqrt{2}} \Rightarrow \phi_2 = 45^\circ$$

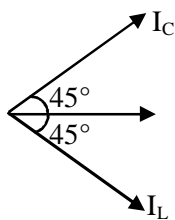

$$I = \sqrt{I_C^2 + I_L^2}$$

$$= \sqrt{2+8}$$

$$= \sqrt{10}$$

$$I = 3.16 \text{ A}$$

Ans. 3.16

19. If the length of the pendulum in pendulum clock increases by 0.1%, then the error in time per day is:

(1) 86.4 s

(2) 4.32 s

(3) 43.2 s

(4) 8.64 s

Official Ans. by NTA (3)

Sol. $T = 2\pi\sqrt{\frac{\ell}{g}}$

$$\frac{\Delta T}{T} = \frac{1}{2} \frac{\Delta \ell}{\ell}$$

$$\Delta T = \frac{1}{2} \times \frac{0.1}{100} \times 24 \times 3600$$

$$\Delta T = 43.2$$

Ans. 3

20. Two blocks of masses 3 kg and 5 kg are connected by a metal wire going over a smooth pulley. The breaking stress of the metal is $\frac{24}{\pi} \times 10^2 \text{ Nm}^{-2}$.

What is the minimum radius of the wire?

(Take $g = 10 \text{ ms}^{-2}$)

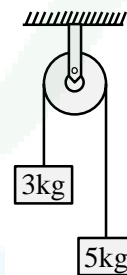

(1) 125 cm

(2) 1250 cm

(3) 12.5 cm

(4) 1.25 cm

Official Ans. by NTA (3)

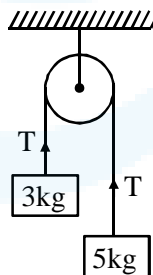

Sol.

$$T = \frac{2m_1 m_2 g}{m_1 + m_2} = \frac{2 \times 3 \times 5 \times 10}{8}$$

$$= \frac{75}{2}$$

$$\text{Stress} = \frac{T}{A}$$

$$\frac{24}{\pi} \times 10^2 = \frac{75}{2 \times \pi R^2}$$

$$R^2 = \frac{75}{2 \times 24 \times 100} = \frac{3}{8 \times 24}$$

$$\Rightarrow R = 0.125 \text{ m}$$

$$R = 12.5 \text{ cm}$$



SECTION-B

1. Two waves are simultaneously passing through a string and their equations are :

$y_1 = A_1 \sin k(x-vt)$, $y_2 = A_2 \sin k(x-vt + x_0)$. Given amplitudes $A_1 = 12$ mm and $A_2 = 5$ mm, $x_0 = 3.5$ cm and wave number $k = 6.28$ cm^{-1} . The amplitude of resulting wave will be mm.

Official Ans. by NTA (7)

Sol. $y_1 = A_1 \sin k(x - vt)$
 $y_1 = 12 \sin 6.28 (x - vt)$
 $y_2 = 5 \sin 6.28 (x - vt + 3.5)$
 $\Delta\phi = \frac{2\pi}{\lambda}(\Delta x)$
 $= K(\Delta x)$
 $= 6.28 \times 3.5 = \frac{7}{2} \times 2\pi = 7\pi$

$$A_{\text{net}} = \sqrt{A_1^2 + A_2^2 + 2A_1A_2 \cos\phi}$$

$$A_{\text{net}} = \sqrt{(12)^2 + (5)^2 + 2(12)(5)\cos(7\pi)}$$

$$= \sqrt{144 + 25 - 120}$$

Ans. 7

2. A source of light is placed in front of a screen. Intensity of light on the screen is I. Two Polaroids P_1 and P_2 are so placed in between the source of light and screen that the intensity of light on screen is $I/2$. P_2 should be rotated by an angle of (degrees) so that the intensity of light on the screen becomes $\frac{3I}{8}$.

Official Ans. by NTA (30)

Sol. $I = \frac{I_0}{2} \cos^2 \phi$

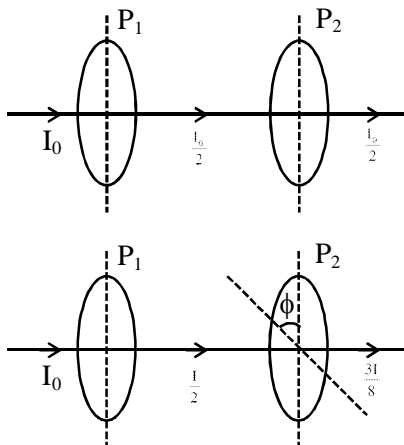

$$\frac{I}{2} \cos^2 \phi = \frac{3I}{8}$$

$$\cos^2 \phi = \frac{3}{4}$$

$$\cos \phi = \frac{\sqrt{3}}{2}$$

$$\Rightarrow \phi = 30$$

Ans. 30

3. If the maximum value of accelerating potential provided by a radio frequency oscillator is 12 kV. The number of revolution made by a proton in a cyclotron to achieve one sixth of the speed of light is

$[m_p = 1.67 \times 10^{-27}$ kg, $e = 1.6 \times 10^{-19}$ C,
 Speed of light = 3×10^8 m/s]

Official Ans. by NTA (543)

Sol. $V = 12$ kV

Number of revolution = n

$$n[2 \times q_p \times V] = \frac{1}{2} m_p \times v_p^2$$

$$n[2 \times 1.6 \times 10^{-19} \times 12 \times 10^3$$

$$= \frac{1}{2} \times 1.67 \times 10^{-27} \times \left[\frac{3 \times 10^8}{6} \right]^2$$

$$n(38.4 \times 10^{-16}) = 0.2087 \times 10^{-11}$$

$$n = 543.4$$

Ans. 543

4. The acceleration due to gravity is found upto an accuracy of 4% on a planet. The energy supplied to a simple pendulum to known mass 'm' to undertake oscillations of time period T is being estimated. If time period is measured to an accuracy of 3%, the accuracy to which E is known as%

Official Ans. by NTA (14)

Sol. $T = 2\pi \sqrt{\frac{\ell}{g}} \Rightarrow \ell = \frac{T^2 g}{4\pi^2}$

$$E = mg\ell \frac{\theta^2}{2} = mg^2 \frac{T^2 \theta^2}{8\pi^2}$$

$$\frac{dE}{E} = 2 \left(\frac{dg}{g} + \frac{dT}{T} \right)$$

$$= (4 + 3) = 14\%$$



5. A circular coil of radius 8.0 cm and 20 turns is rotated about its vertical diameter with an angular speed of 50 rad s^{-1} in a uniform horizontal magnetic field of $3.0 \times 10^{-2} \text{ T}$. The maximum emf induced the coil will be $\times 10^{-2}$ volt (rounded off to the nearest integer)

Official Ans. by NTA (60)

Sol. Maximum emf $\epsilon = N \omega AB$

$$N = 20, \omega = 50, B = 3 \times 10^{-2} \text{ T}$$

$$\epsilon = 20 \times 50 \times \pi \times (0.08)^2 \times 3 \times 10^{-2} = 60.28 \times 10^{-2}$$

Rounded off to nearest integer = 60

Ans. 60

6. Two simple harmonic motions are represented by the equations

$$x_1 = 5 \sin \left(2\pi t + \frac{\pi}{4} \right) \text{ and } x_2 = 5\sqrt{2} (\sin 2\pi t + \cos 2\pi t).$$

The amplitude of second motion is times the amplitude in first motion.

Official Ans. by NTA (2)

Sol. $x_2 = 5\sqrt{2} \left(\frac{1}{\sqrt{2}} \sin 2\pi t + \frac{1}{\sqrt{2}} \cos 2\pi t \right) \sqrt{2}$

$$= 10 \sin \left(2\pi t + \frac{\pi}{4} \right)$$

$$\therefore \frac{A_2}{A_1} = \frac{10}{5} = 2$$

Ans. 2

7. A coil in the shape of an equilateral triangle of side 10 cm lies in a vertical plane between the pole pieces of permanent magnet producing a horizontal magnetic field 20 mT. The torque acting on the coil when a current of 0.2 A is passed through it and its plane becomes parallel to the magnetic field will be $\sqrt{x} \times 10^{-5} \text{ Nm}$. The value of x is.....

Official Ans. by NTA (3)

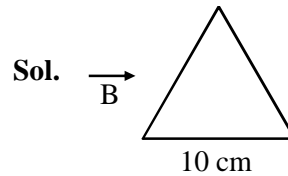

$$\vec{\tau} = \vec{M} \times \vec{B} = MB \sin 90^\circ$$

$$= MB = \frac{i\sqrt{3}l^2}{4} B$$

$$= \sqrt{3} \times 10^{-5} \text{ N-m}$$

Ans. 3

8. For the given circuit, the power across zener diode is mW.

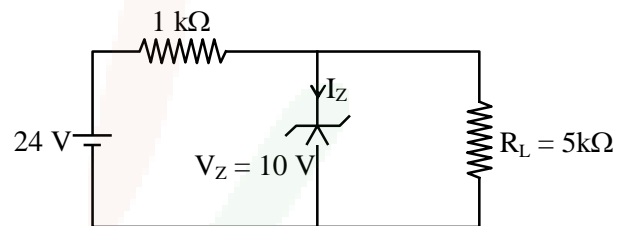

Official Ans. by NTA (120)

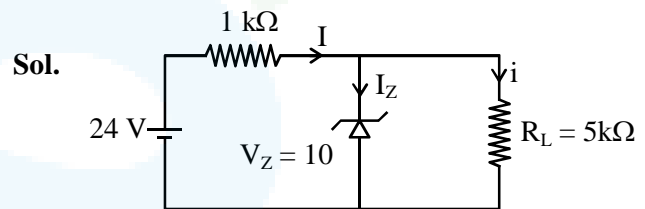

$$i = \frac{10\text{V}}{5\text{k}\Omega} = 2\text{mA}$$

$$I = \frac{14\text{V}}{1\text{k}\Omega} = 14\text{mA}$$

$$\therefore I_z = 12\text{mA}$$

$$\therefore P = I_z V_z = 120 \text{ mW}$$

Ans. 120

9. An object is placed at a distance of 12 cm from a convex lens. A convex mirror of focal length 15 cm is placed on other side of lens at 8 cm as shown in the figure. Image of object coincides with the object.

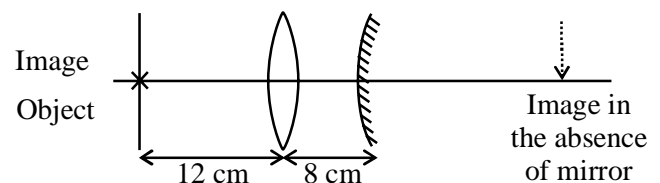

When the convex mirror is removed, a real and inverted image is formed at a position. The distance of the image from the object will be(cm)

Official Ans. by NTA (50)

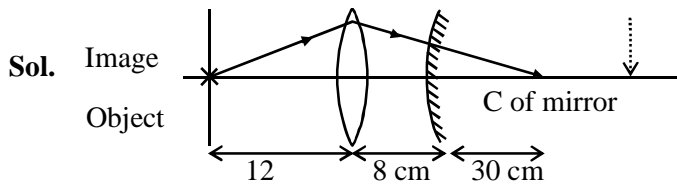

For the object to coincide with image, the light must fall perpendicularly to mirror. Which means that the light will have to converge at C of mirror.

Without the mirror also, the light would coverage at C.

So the distance is : $12 + 8 + 30 = 50$ cm

- 10.** The coefficient of static friction between two blocks is 0.5 and the table is smooth. The maximum horizontal force that can be applied to move the blocks together isN.

(take $g = 10 \text{ ms}^{-2}$)

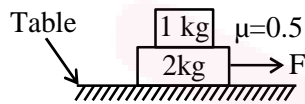

Official Ans. by NTA (15)

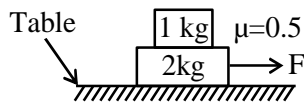

Sol.

$$F = 3a \text{ (For system)} \quad \dots(i)$$

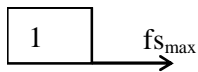

$$f_{s_{\max}} = 1a \text{ (for 1kg block)} \quad \dots(ii)$$

$$\mu \times 1 \times g = a$$

$$\Rightarrow 5 = a$$

$$F = 15\text{N}$$